

Application Note 283-3



Low Phase Noise Applications of the HP 8662A and 8663A Synthesized Signal Generators



Table of Contents

Chapter 1	
Introduction	4
Chapter 2	
The Phase Noise Density Spectrum and its Implications	5
What is Phase Noise	
Different Measures of Short-Term Frequency Stability	
SSB Phase Noise Definitions	
Residual and Absolute Phase Noise	
Why is Phase Noise Important	
Local Oscillator Applications	
Doppler Radar Applications	
Out-of-Channel Receiver Testing	
Chapter 3	
The HP 8662A/8663A: Designed for Low Phase Noise	9
Theory of Operation	
The Reference Section	
The Phase-Locked Loop Section	
High-Frequency Loops	
Low-Frequency Loops	
The Output Section	
Chapter 4	
Improving Frequency Stability with External References	12
Why Use an External Reference	
Reference Effects on Long-Term Stability	
Effect on the Reference on Short-Term Stability	
HP 8662A/8663A Stability Using a Cesium-Beam Reference	
Effect of an Arbitrary Reference	
Chapter 5	
SSB Phase Noise Measurement	16
Common Measurement Methods	
Two-Source Technique—Basic Theory	
Importance of Quadrature	
Phase-Locked Measurements	
Chapter 6	
Measuring SSB Phase Noise With the HP 8662A/8663A	19
SSB Phase-Noise Measurements on Sources	
Operating From a Common Reference	
Component Considerations	
The Phase Detector	
The Low-Pass Filter	
The Spectrum Analyzer	
Measurement Procedure	
Calibration	
Setting Quadrature	
Measurement	
Precautions	
Phase-Locked Measurements Using the HP 8662A/8663A	
Phase-Locked Measurement Procedure	
Calibration	
Setting Quadrature	
Measurement	
Comments	
Automated SSB Phase Noise Measurements Using the HP-IB	

Chapter 7	
Using the HP 8662A/8663A at Microwave Frequencies With the HP 3048A Phase Noise Measurement System	26
Why Use the HP 8662A/8663A at Microwave Frequencies	
Effect of Multiplication on Signal Noise	
HP 8662A/8663A Phase Noise Performance at Microwave Frequencies	
Using the HP 8662A/8663A and the HP 11740A for Low-Noise Microwave Signal Generation	
Using the HP 3047A/11740A to Make Phase-Noise Measurements on Microwave Sources	
Measurement Techniques	
Data Interpretation	
HP 3048A/11740A System Performance	
Measurements on Pulsed Sources	
Summary	
Chapter 8	
Voice Grade Receiver Testing With the HP 8662A/8663A	33
Receiver Test Basics: In-Channel and Out-of-Channel Testing	
Using the HP 8662A/8663A for Adjustment Channel Receiver Tests	
Using the HP 8662A/8663A for Spurious Attenuation Testing	
Chapter 9	
HP 8662A/8663A as an External LO with the HP 8901A/B Modulation Analyzer and HP 8902 Measuring Receiver	37
Measured Performance	
Measurement Considerations and Procedure	
Chapter 10	
Using an HP 8662A/8663A With the HP 8505A RF Network Analyzer	39
Measurement Setup	
Typical Operating Characteristics	
Frequency Characteristics Range and Resolution	
Typical System Residual FM	
Output Characteristics	
Delay and Electrical Length Characteristics	
Chapter 11	
Using the HP 8662A/8663A as a Substitute LO With the HP 8672A Microwave Synthesized Signal Generator	41
System Operation	
Hardware Modifications	
System Performance	
Resolution	
Frequency Algorithm	
Modulation	
Chapter 12	
Fast Frequency Switching With the HP 8662A/8663A	44
Standard HP-IB Frequency Control	
Fast Learn Frequency Switching	
Fast Frequency Switch Option H-50	
Summary	
Appendix A	
Calibration of Phase Noise of Three Unknown Sources	50
Appendix B	
10 MHz Low-Noise Bandpass Amplifier	50
Appendix C	
Low-Noise Amplifier	50
Appendix D	
References	51
Hewlett-Packard Applications Notes	
Other References	

Chapter 1

Introduction

	HP 8662A	HP 8663A
FREQUENCY		
Range (MHz)	0.01 to 1280	0.1 to 2560
Resolution (Hz)	0.1 to 0.2	0.1 to 0.4
Stability	5×10^{-10} /day	5×10^{-10} /day
OUTPUT		
Range (dBm)	+13 to -140	+16 to -130
Resolution (dB)	0.1	0.1
Accuracy (dB)	± 1	± 1
MODULATION		
Internal	AM, FM	AM, FM, Phase, Pulse
External	AM, FM	AM, FM, Phase, Pulse
SPECTRAL PURITY		
Harmonics (-dBc)	<30	<30
Spurious (-dBc) in 320 to 640 MHz band	<90	<90

TABLE 1.1.
HP 8662A/8663A Performance Comparison

The stringent performance requirements of modern radar and communications systems call for high frequency signals with extremely good spectral purity. The Hewlett-Packard 8662A and 8663A Synthesized Signal Generators provide extremely good overall spectral purity by combining the low close in phase noise of a frequency synthesizer with the low spurious and noise floor typically found only in cavity-tuned generators. These characteristics make the HP 8662A and HP 8663A excellent choices for many low noise applications, particularly as local oscillators in low noise systems, low noise RF signals when multiplied up in frequency, or as versatile signal simulators through their flexible modulation formats. The HP 8662A operates up to 1280 MHz and is well suited to radio receiver testing by providing simultaneous AM and FM modulation. The HP 8663A covers another frequency octave, up to 2560 MHz, for applications in the low S-band range and provides simultaneous AM, FM, phase and pulse modulation. This allows simulation of radar returns and transmitted communications signals.

The HP 8662A and the HP 8663A share the same frequency synthesis circuitry and therefore yield the same spectral purity. Their performance differs primarily in frequency range, output power level, and modulation format. Table 1.1 and Figure 1.1 illustrate the HP 8662A and HP 8663A performance similarities and differences.

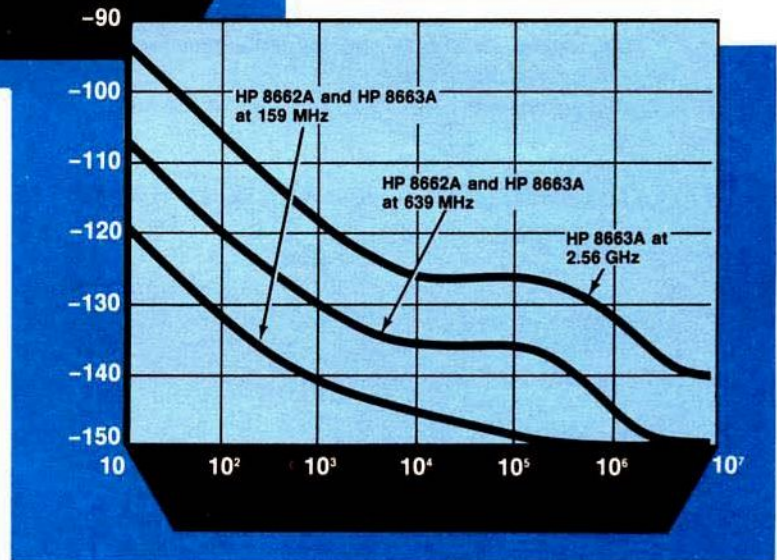

Figure 1.1.
Measured Residual SSB phase noise versus offset from carrier. Carrier frequency 159 MHz, 639 MHz and 2.56 GHz

This application note discusses phase noise in detail (Chapter 2) to provide an understanding of its implications for certain critical applications such as out-of-channel receiver testing, doppler radar, and local oscillator substitution.

In Chapter 3, key design aspects of the HP 8662A and HP 8663A, and the resulting phase noise performance, are presented, followed in Chapter 4 by a discussion of the effects of external references on their performance. Chapters 5 and 6 present techniques of applying the excellent phase-noise performance of the HP 8662A/8663A to solve problems that commonly arise in the measurement of low phase noise. Chapter 7 extends these techniques to the microwave frequency range via HP 8662A/8663A-based systems specifically intended to measure low phase noise microwave signals.

The effects of signal generator phase noise on receiver testing are discussed in Chapter 8. The next three chapters present methods of applying the HP 8662A/8663A to enhance the performance of several other Hewlett-Packard instruments. Finally, Chapter 12 discusses the fast frequency switching capability of the HP 8662A/8663A.

Chapter 2

The Phase Noise Density Spectrum and Its Implications

What is Phase Noise?

Every RF or microwave signal displays some frequency instability. A complete description of such instability is generally broken into two components, long-term and short-term. Long-term frequency stability, commonly known as frequency drift, describes the amount of variation in signal frequency that occurs over long time periods – hours, days, or even months. Short-term frequency stability refers to the variations that occur over time periods of a few seconds or less. This application note deals primarily with short-term frequency stability.

DIFFERENT MEASURES OF SHORT-TERM FREQUENCY STABILITY

There are a number of methods for specifying short-term frequency stability. Three of these methods, fractional frequency deviation, residual FM, and single sideband (SSB) phase noise are discussed in this chapter.

Fractional frequency deviation uses a time domain measurement in which the frequency of the signal is repeatedly measured with a frequency counter, with the time period of each measurement held constant. This allows several calculations of the fractional frequency difference, y , over a time period, τ . A special variance of these differences, called the Allan variance, can then be calculated. The square root of this variance is $\sigma(\tau)$. The whole process is generally repeated for several different time periods, or τ , and $\sigma(\tau)$ is plotted versus τ as an indication of the signal's short-term frequency stability. (See also NBS Technical Note 394, "Characterization of Frequency Stability", reference 9 in Appendix D.)

The second method of specifying short-term frequency stability is residual FM. This is a frequency-domain technique in which the signal of interest is examined using an FM discriminator followed by a filter. The bandwidth of the filter is set at some specified value, usually 300 Hz to 3 kHz, and the rms noise voltage at the filter output is proportional to the frequency deviation in Hz. In this method, only the total short-term frequency instability occurring at rates that fall within the filter bandwidth is indicated. No information regarding the relative weighting or distribution of instability rates is conveyed.

For this reason, the use of residual FM to specify the short-term stability of a signal generally provides the least amount of information of the methods listed. An additional disadvantage is that different post-detection bandwidths are specified in different measurement standards. For example, another common choice is 20 Hz to 15 kHz. As a result, quite often comparisons of oscillator performance based on residual FM specifications cannot be made directly. However, for many communications systems, residual FM is used because it matches the terms and conditions of the application.

Single sideband (SSB) phase noise measures short-term instabilities as low-level phase modulation of the signal carrier. Due to the random nature of the instabilities, the phase deviation must be represented by a spectral density distribution plot known as an SSB phase noise plot, see Figure 2.2.

Of all the methods commonly in use, SSB phase noise has the advantage of providing the most information about the short-term frequency stability of a signal. In addition, both fractional frequency deviation and residual FM may be derived if the phase noise distribution of a signal is known. As a result, SSB phase noise has become the most widely used method of specifying short-term stability. For this reason, the majority of this application note is devoted to SSB phase noise to specify short-term frequency stability.

SSB PHASE NOISE DEFINITIONS

Due to phase noise, in the frequency domain a signal is not a discrete spectral line, but "spreads out" over frequencies both above and below the nominal signal frequency in the form of modulation sidebands. Figure 2.1 illustrates the difference between ideal and real signals in the frequency domain. In some cases, phase-noise sidebands can actually be viewed and measured directly on a spectrum analyzer. This has led to the common definition of phase noise in which the phase-noise level is represented by a function $\mathcal{L}(f)$ called "script L". The U.S. National Bureau of Standards defines $\mathcal{L}(f)$ as the ratio of the power in one sideband, on a per-Hertz-of-bandwidth spectral-density basis, to the total signal power, at an offset (modulation) frequency f from the carrier. $\mathcal{L}(f)$ is a normalized frequency-domain measure of phase-fluctuation sidebands expressed as dB relative to the carrier per Hz (dBc/Hz).

$$\mathcal{L}(f) = \frac{\text{Power Density (One Phase Modulation Sideband)}}{\text{Total Signal Power}} \frac{\text{dBc}}{\text{Hz}}$$

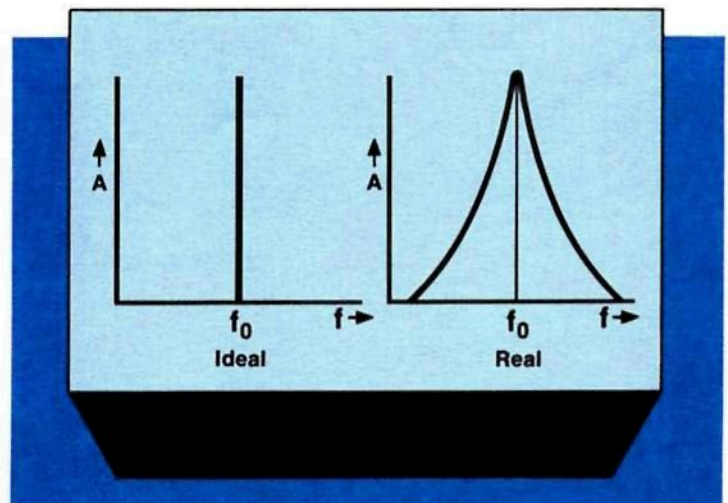

Figure 2.1. CW signal viewed in the frequency domain.

As mentioned, $\mathcal{L}(f)$ can be measured directly on a spectrum analyzer if the following conditions are met:

1. The spectrum analyzer noise floor is lower than the level of phase noise being measured. This means that the phase noise of the spectrum analyzer's local oscillator must be lower than the level of the noise being measured. In addition, the dynamic range and selectivity of the analyzer must be sufficient to discern the measured phase noise.
2. The signal's AM noise does not make a significant contribution to the noise measured. This can be determined by measuring the AM noise of the signal, or it can be deduced by understanding the nature of the source under test.

For more information on how to measure phase noise directly on spectrum analyzers, refer to Hewlett-Packard Application Note 270-2, "Automated Noise Sideband Measurements Using the HP 8568A Spectrum Analyzer".

Another function frequently encountered in phase noise work is $S_{\phi}(f)$. $S_{\phi}(f)$ is the spectral density of the phase fluctuations in radians squared per Hz. The relationship between $S_{\phi}(f)$ and $\mathcal{L}(f)$ is simply:

$$\mathcal{L}(f) = \frac{S_{\phi}(f)}{2}$$

This relationship, however, only applies if the mean-square phase deviations are

small relative to one radian. Close-in to the carrier this criterion may be violated. The plot of $\mathcal{L}(f)$ resulting from the phase noise of a free running VCO (Figure 2.2) illustrates the erroneous results that can occur if the rms phase deviation in a particular measurement exceeds a small angle. Approaching the carrier, $\mathcal{L}(f)$ is increasingly in error, eventually exceeding the carrier amplitude and reaching a level of +45 dBc/Hz at a 1 Hz offset (45 dB more noise power at a 1 Hz offset in a 1 Hz bandwidth than the total power in the signal).

The -10 dB/decade line drawn on Figure 2.2 represents an rms phase deviation of approximately 0.2 radians integrated over any one decade of offset frequency. At approximately 0.2 radians, the power in the higher order sidebands of the phase modulation is still insignificant compared to the power in the first order sideband. This ensures that the simple calculation of $\mathcal{L}(f)$ from $S_{\phi}(f)$ is valid (the mean square phase fluctuations are small relative to one radian squared). Below this line the plot of $\mathcal{L}(f)$ is correct; above the line $\mathcal{L}(f)$ is invalid and $S_{\phi}(f)$ is used to represent the noise of the signal. The data above the line must be interpreted in radians squared per Hertz, not in dBc/Hz as $\mathcal{L}(f)$ is defined. In addition, the vertical scale must be adjusted by 3 dB since $S_{\phi}(f)/2$ is actually graphed.

$S_{\phi}(f)$ and $\mathcal{L}(f)$ are discussed further in Chapter 5, where the two-source method of measuring phase noise is described.

RESIDUAL AND ABSOLUTE PHASE NOISE

There are two measures of phase noise commonly used in specifying the short-term stability of signals – residual phase noise and absolute phase noise. Residual phase noise refers to that noise inherent in (added by) a signal processing device, independent of the noise of the reference oscillator driving it. Absolute phase noise is the total phase noise present at the device output and is a function of both the reference-oscillator noise and the residual phase noise of the device. Absolute phase noise is the parameter generally considered.

Residual phase noise is used to help understand the additive noise generated in frequency synthesizers. Although most synthesizers have internal reference oscillators, many synthesizer users prefer to use external references of higher stability to improve the synthesizer performance or to synchronize a system of many instruments. In these cases, the residual noise specification conveys more information than the absolute noise specification, since it allows the user to calculate absolute noise performance from the characteristics of his own reference oscillator. Chapter 4 discusses the effects of external references on the absolute noise of the HP 8662A and 8663A.

Why is Phase Noise Important?

In recent years, advances in radar and communications technology have pushed system performance to levels previously unattainable. Design emphasis on system sensitivity and selectivity has resulted in dramatic improvements in those areas. However, as factors previously limiting system performance have been dealt with, new limitations have emerged upon which attention is being focused. One of these limitations is phase noise. The ability to generate and measure low-phase-noise RF and microwave signals has become more important than ever before.

Because of extremely low SSB phase noise, the HP 8662A/8663A allow users to meet these critical phase noise requirements with off the shelf equipment. To illustrate how low phase noise sources such as the HP 8662A/8663A can help achieve better system performance, three specific applications are presented.

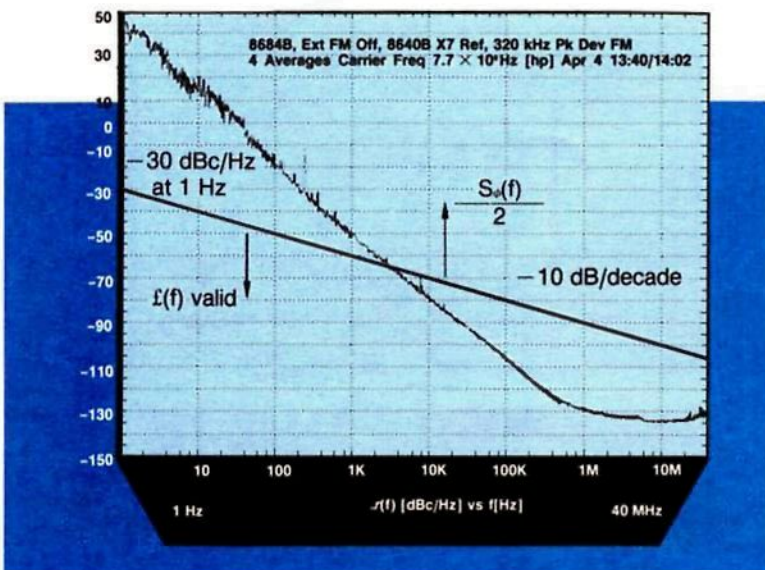

Figure 2.2. Region of Validity of $\mathcal{L}(f) = \frac{S_{\phi}(f)}{2}$

LOCAL-OSCILLATOR APPLICATIONS

Phase noise can be a major limiting factor in high performance frequency-conversion applications dealing with signals that span a wide dynamic range. The first down conversion in a high-performance superheterodyne receiver serves as a good example for illustration. Suppose that two signals (Figure 2.3a) are present at the input of such a receiver. These signals are to be mixed with a local oscillator signal down to an intermediate frequency (IF) where highly selective IF filters can separate one of the signals for amplification, detection, and baseband processing. If the desired signal is the larger signal, there should be no difficulty in recovering it, if the receiver is correctly designed.

signal can degrade a receiver's useful dynamic range as well as its selectivity. To achieve the best performance from a given receiver design, its local-oscillator phase noise must be minimized. This is where the HP 8662A/8663A can help. First the HP 8662A/8663A can provide a low-phase-noise signal to serve as the reference when measuring the phase noise of the local-oscillator signal under test. This measurement is described in detail in Chapters 5 and 6. Second, the HP 8662A/8663A can provide the local-oscillator signal itself. With +16 dBm typical output power, 0.1 Hz frequency resolution, 420/510 microsecond frequency switching speed, and full HP-IB programmability, the HP 8662A/8663A can serve in almost any demanding local-oscillator application.

DOPPLER RADAR APPLICATIONS

Doppler radars determine the velocity of a target by measuring the small doppler shifts in frequency that the return echoes have undergone. Return echoes of targets approaching the radar (closing targets) are shifted higher in frequency than the transmitted carrier, while return echoes of targets moving away from the radar (opening targets) are shifted lower in frequency. Unfortunately, the return signal includes much more than just the target echo. In the case of an airborne radar, the return echo also includes a large "clutter" signal which is basically the unavoidable frequency-shifted echo from the ground. Figure 2.4 shows the typical return frequency spectrum of an airborne pulsed-doppler radar. In some situations, the ratio of main-beam clutter to target signal may be as high as 80 dB. This makes it difficult to separate the target signal from the main-beam clutter. The problem is greatly aggravated when the received spectrum has frequency instabilities—high phase noise—caused by either the transmitter oscillator or the receiver LO. Such phase noise on the clutter signal can partially or totally mask the target signal, depending on the relative level of the target signal and its frequency separation from the clutter signal. Recovering the target signal is most difficult when the target is moving slowly and is close to the ground because then the ratio of clutter level to target level is high and the frequency separation between the two is low.

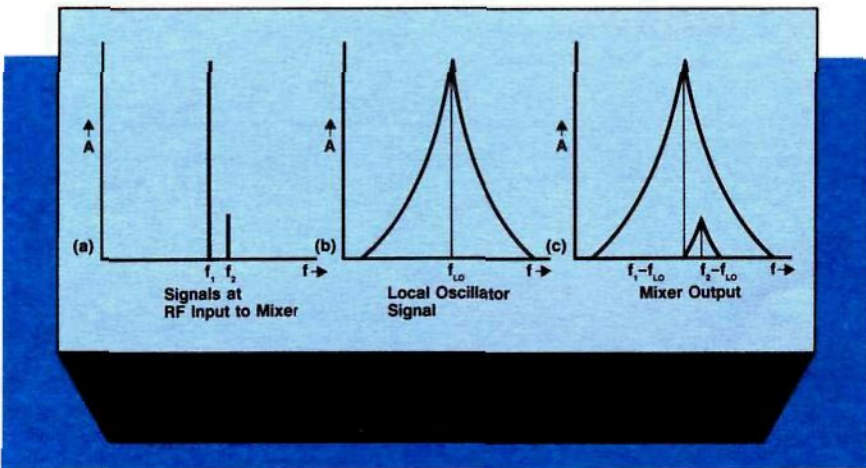

Figure 2.3.
Effect of L.O. phase noise in mixer application.

A problem may arise, however, if the desired signal is the smaller of the two, because any phase noise on the local-oscillator signal is translated directly to the mixer products. Figures 2.3b and c show this effect. Notice that the translated noise in the mixer output completely masks the smaller signal. Even though the receiver's IF filtering may be sufficient to remove the larger signal's mixing product, the smaller signal's mixing product is no longer recoverable due to the translated local-oscillator noise. This effect is particularly noticeable in receivers of high selectivity and wide dynamic range.

The key point here is that the phase-noise level of the local-oscillator signal often determines the receiver's performance. A noisy local-oscillator

This effect is similar to that in the local-oscillator application described in the preceding section. A small signal, the target echo, must be discerned in the

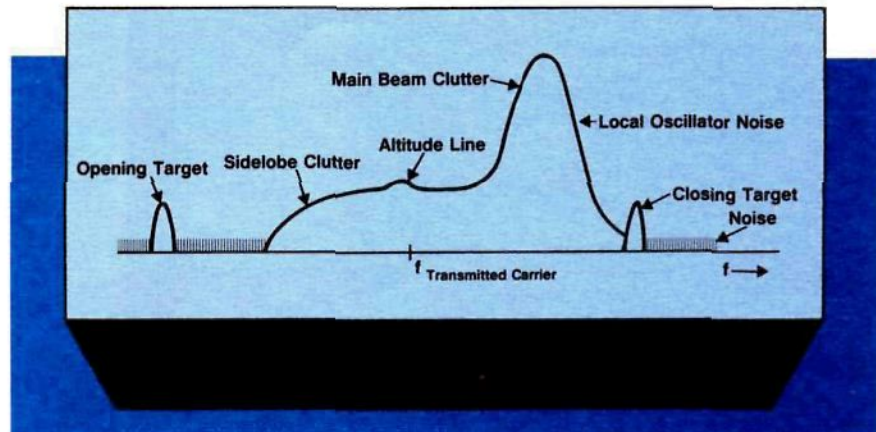



Figure 2.4.
Typical return spectrum for airborne doppler radar.



presence of the much larger clutter signal that is very close in frequency. Again, the system performance is limited by phase noise. In this case, it is the phase-noise level of either the transmitter oscillator or the receiver local oscillator that is limiting.

The HP 8662A/8663A can improve the radar's performance by serving as a low-phase-noise source for phase-noise measurement or signal substitution. Since most radars operate at microwave frequencies, it is usually necessary to multiply the generator's outputs to the microwave frequency range. This multiplication is discussed in Chapter 7.

OUT-OF-CHANNEL RECEIVER TESTING

Modern communications receivers have excellent selectivity and spurious rejection characteristics. These are called the out-of-channel characteristics and require very high quality test signals for verification. Typically, two signal generators are used for testing the out-of-channel characteristics of a receiver. One generator is tuned in channel, the other is tuned out of channel, typically one channel spacing away.

Due to the masking effect described for local oscillator applications, the phase noise and AM noise of the out-of-channel generator may limit the selectivity that can be measured. As a result, the measured selectivity may be much worse than the actual receiver selectivity. The limiting level of phase noise on the out-of-channel generator is determined by the level of performance of the receiver that is being measured. More selective receivers require lower phase noise on the out-of-channel generator. Out-of-channel receiver testing and the phase noise requirements of the out-of-channel generator are described in more detail in Chapter 8.

Chapter 3

The HP 8662A/8663A: Designed for Low Phase Noise

The HP 8662A and HP 8663A Synthesized Signal Generators offer a superior combination of spectral purity, frequency resolution, and frequency switching speed in programmable RF signal generators. To understand how these products achieve such performance, it is necessary to examine their basic operation.

Theory of Operation

Figures 3.1 and 3.2 show the basic block

reference section synthesizes many different frequencies from a high stability 10 MHz quartz oscillator. The phase-locked loop section uses these reference-section signals to synthesize output frequencies of 320 to 640 MHz in 0.1 Hz steps. The output section modulates and amplifies the output signal from the phase-locked loop section and translates its frequency to the desired output frequency. This frequency translation is done by doubling, dividing, or mixing.

signals are used as a basis for synthesizing the final output signal.

All of the reference section signals are directly synthesized; i.e., they are derived by multiplying, mixing, and dividing from an internal high stability 10 MHz reference oscillator. As a result, the long-term frequency stability of the HP 8662A/8663A is derived directly from the internal reference and is specified to be less than 5×10^{-10} per day after a 10-day warmup. As an example of how stable this is, when the HP 8662A/8663A is set for an output frequency of 500 MHz, the frequency will drift no more than a quarter of a hertz per day after the specified warmup!

The frequency accuracy of the HP 8662A/8663A is directly related to the frequency accuracy of the internal reference oscillator. The reference frequency can be mechanically adjusted over a range of about 20 Hz to allow close calibration against a standard. The frequency accuracy of the output is dependent on: 1) how closely the internal reference oscillator is adjusted to match an accepted standard and 2) how far the reference oscillator drifts over time (the primary drift component is crystal aging, specified to be less than 5×10^{-10} /day). For most applications, the stability of the internal reference is adequate.

If greater stability is required, provision has been made in the HP 8662A/8663A to substitute an external 5 or 10 MHz reference for the internal reference. A cesium or rubidium standard used as an external reference can provide frequency accuracies on the order of one part in 1×10^{11} . Such an atomic standard may also provide improved phase noise at some offsets compared to the internal reference. The use of external references with the HP 8662A/8663A is discussed in Chapter 4.

Figure 3.1. HP 8662A block diagram.

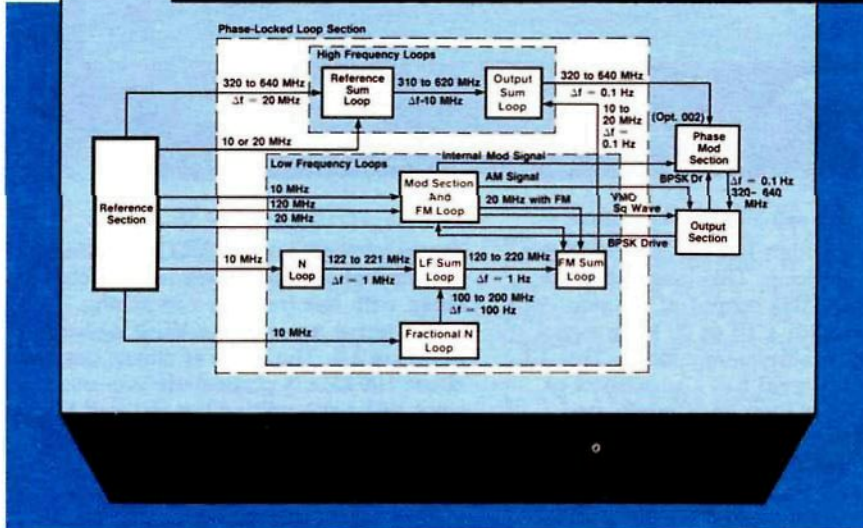
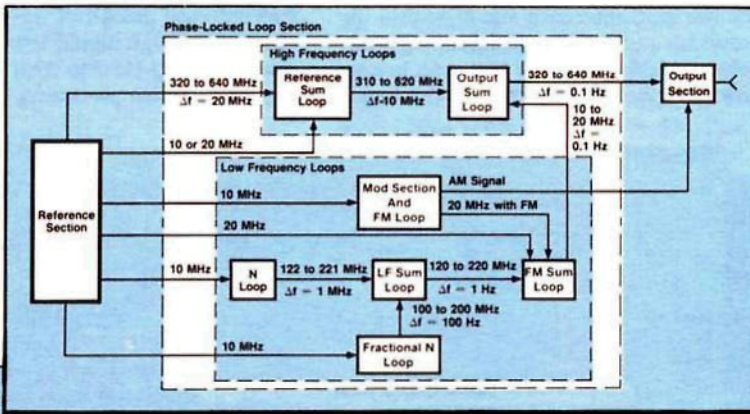

Figure 3.2. HP 8663A block diagram.

diagrams for the HP 8662A and HP 8663A, respectively. The HP 8662A and HP 8663A block diagrams are fundamentally the same. The major differences are attributable to an extended frequency range and the addition of pulse and phase modulation in the HP 8663A. In general, the block diagram can be divided into three main sections: the reference section, the phase-locked loop section, and the output section. The ref-

THE REFERENCE SECTION

The main function of the reference section is to provide a synthesized octave band of frequencies from 320 to 640 MHz in 20 MHz steps. The reference section also generates frequencies of 10, 20, 120, and 520 MHz for use as local-oscillator signals in the phase-locked loop and output sections. Both the short-term and long-term frequency stability of the signals from the reference section are critical, since these

The short-term frequency stability or phase noise of the reference oscillator affects the phase noise on the HP 8662A/8663A output signal. Although the internal reference has very low inherent phase noise, as its frequency is multiplied up to produce the higher frequency reference section signals, the phase noise also increases at a rate of 6 dB/octave. To reduce this effect, monolithic crystal filters in the reference multiplier chain at 40 and

160 MHz filter the noise sidebands at offsets greater than about 4 kHz. The resulting phase noise of the reference section output at 500 MHz is typically -110 dBc (dB relative to the carrier) at a 10 Hz offset decreasing to a noise floor of about -148 dBc at offsets greater than 10 kHz.

The mechanical configuration of the crystal filters is critical, since any small mechanical vibrations in the filter translate directly into microphonic spurious sidebands on the signal. The most common source of instrument vibration is the cooling fan which causes spurious signals at about 53 Hz offsets with 60 Hz power lines. This spurious mechanism is minimized in the HP 8662A/8663A by a special shock mounting arrangement which mechanically isolates the crystal filters from instrument vibration and by dynamically balancing each fan before installation in the instrument.

THE PHASE-LOCKED LOOP SECTION

The phase-locked loop section consists of seven phase-locked loops that provide the frequency programmability, frequency modulation, and fine frequency resolution of the HP 8662A/8663A without compromising the excellent frequency stability and spectral purity of the reference section. Using an indirect-synthesis technique (i.e., synthesis using phase-locked loops as contrasted with direct synthesis by mixing, multiplying, or dividing as is done in the reference section), the phase-locked loop section takes the 320 to 640 MHz in 20 MHz steps from the reference section and synthesizes an output of 320 to 640 MHz in 0.1 Hz steps.

The phase-locked loop section is divided into two areas, the high-frequency loops and the low-frequency loops. The two high-frequency loops are nearly identical with specially designed, low-noise voltage-controlled oscillators (VCOs). The low-frequency loops consist of five phase-locked loops; three that provide the HP 8662A/8663A's 0.1 Hz frequency resolution and two which generate frequency modulation and sum the resulting FM signal with the final output signal.

High-Frequency Loops

The first of the two high-frequency loops, the reference sum loop, tunes over a 310 to 620 MHz frequency range.

This loop sums the reference section's main output of 320 to 640 MHz with 10 or 20 MHz also from the reference section. The reference sum loop's primary function is to filter out spurious signals on the reference section output beyond the loop bandwidth and to improve the resolution from 20 MHz steps to 10 MHz steps. The loop provides 60 dB of spectral filtering, thereby reducing the spurious level from -40 dBc to -100 dBc. Such filtering is an advantage of indirect synthesis, since the bandwidth of the phase-locked loop can be set so that the loop VCO will only track the loop reference signal within the bandwidth of the loop. Reference signal sidebands falling outside the loop bandwidth are therefore rejected by the loop.

switched-reactance resonator of novel design (Figure 3.3). The resonator consists of an array of five inductors switched in a binary sequence to provide 32 frequency steps. Thus, for continuous frequency coverage of 320 to 640 MHz, the varactor has to tune over only 10 MHz spans. Compared to a conventional VCO with a varactor covering the entire 320 to 640 MHz frequency range, this switched scheme results in greatly reduced oscillator tuning sensitivity. Therefore, any noise on the VCO tuning line causes very little phase noise as compared with a conventional VCO. In addition, the design of the oscillator yields very high signal levels (± 10 volts peak), high Q (150 to 250), fast switching, and precise pretuning.

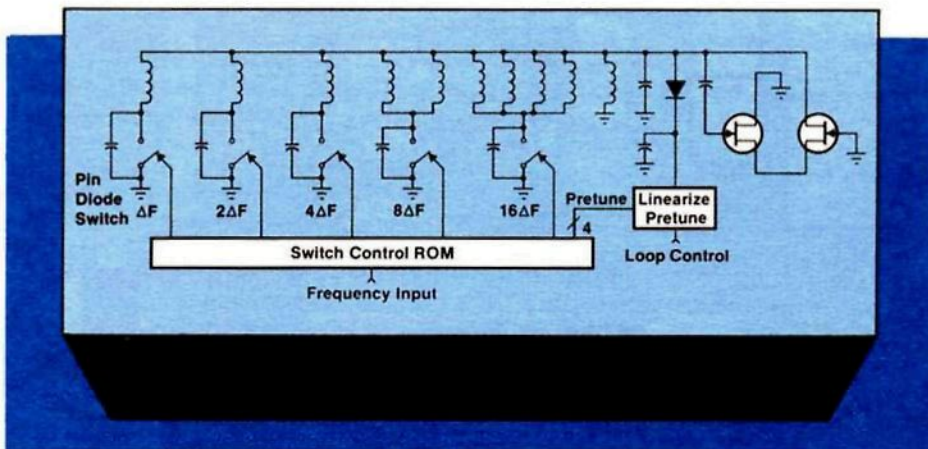

Figure 3.3. 320 to 640 MHz switched reactance oscillator.

The second high-frequency loop is the output sum loop. This loop sums the 310 to 620 MHz output of the reference sum loop with a 10 to 20 MHz signal from the low-frequency loops. This 10 to 20 MHz signal has a resolution of 0.1 Hz and is frequency modulated when FM is enabled. The resulting output from the output sum loop is 320 to 640 MHz in 0.1 Hz steps. In the HP 8662A, this signal is sent to the output section for translation to the final output frequency and amplitude modulation. In the HP 8663A, this signal is sent to the phase modulator (if phase modulation option 002 is included) and then to the output section for translation to the final HP 8663A frequency, amplitude, pulse, and BPSK modulation.

The reference sum loop and the output sum loop are nearly identical, since they both contain identical, specially designed low-noise VCO's. These VCOs employ a

These properties of the VCOs result in excellent phase noise performance combined with fast frequency switching. The actual phase noise of the VCO is shown in Figure 3.4. The noise at offsets beyond about 100 kHz is particularly important since this noise will not be reduced by the action of the phase-locked loop as will the noise closer in.

Several important considerations were taken into account in the design of the loops that phase-lock these VCOs. Using the reference sum loop as an example, to get the lowest possible overall phase noise, the loop bandwidth was selected to minimize the noise contributions of both the VCO and the reference section. The special efforts made to lower the noise in the reference section allow a relatively wide loop bandwidth (250 to 450 kHz).

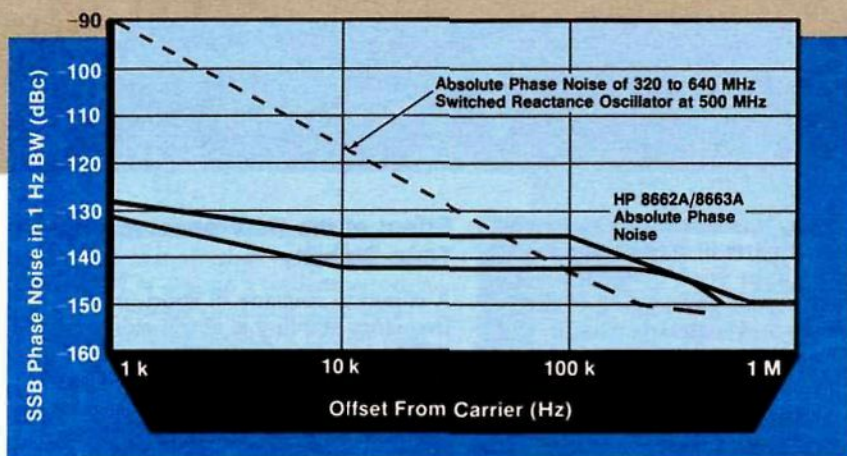

Figure 3.4. Typical phase noise of HP 8662A/8663A switched reactance oscillator.

A direct consequence of wide bandwidth is faster frequency switching. As a result, the reference sum loop can switch in about 50 microseconds. This is particularly significant considering the overall phase noise of the reference sum loop, also shown in Figure 3.4. The reference phase-locked loop filters the close-in noise of the VCO, to provide the resulting absolute phase noise of the HP 8662A/8663A as shown (Figure 3.4).

This combination of both low noise and fast frequency switching is difficult to achieve in synthesizer design. The incorporation of these characteristics distinguish the HP 8662A/8663A from other signal generators, for example, in low-noise applications for doppler radar, and in fast switching applications for anti-jam communications systems. The fast switching capability of the HP 8662A/8663A is discussed in Chapter 12.

Low-Frequency Loops

Careful design in the low-frequency loops optimizes the tradeoffs between resolution, switching speed, and phase noise of the 10 to 20 MHz signal from these loops. Fractional-N techniques sim-

ilar to those used in lower-frequency HP Synthesizers (Models 3325A, 3326A and 3335A) are used in both the "N Loop" and the "Fractional N Loop". In the N Loop, an uncorrected fractional-N technique achieves 1 MHz resolution while minimizing the multiplication of phase noise by using a low divide number. The Fractional N Loop uses a corrected fractional-N technique to achieve 0.1 Hz overall resolution with a relatively low spurious content. This loop is the primary determinant of the overall frequency switching speed of the HP 8662A/8663A. It has a settling time of about 400 microseconds.

The overall phase noise of the 10 to 20 MHz low frequency loop is about -145 dBc at a 10 kHz offset.

THE OUTPUT SECTION

The output section translates the 320 to 640 MHz signal from the phase-locked loop section to the desired HP 8662A/8663A output frequency by doubling, dividing, or mixing, and modulates the signal as previously discussed in the high-frequency loop section. This process produces distinct frequency bands covering the HP 8662A and 8663A frequency ranges, as shown in Table 3.1.

	HP 8662A	HP 8663A
Frequency Range	0.01 to 1280 MHz	0.1 to 2560 MHz
Heterodyne Band	0.01 to 120 MHz	0.1 to 120 MHz
Divide-by-4 Band	120 to 160 MHz	120 to 160 MHz
Divide-by-2 Band	160 to 320 MHz	160 to 320 MHz
Fundamental Band	320 to 640 MHz	320 to 640 MHz
1st Doubled Band	640 to 1280 MHz	640 to 1280 MHz
2nd Doubled Band	(not applicable)	1280 to 2560 MHz

Table 3.1. HP 8662A/8663A frequency bands.

The ways in which these bands are derived determine the short-term stability characteristics and the maximum available peak FM deviation of each band. For example, since frequency doubling results in a 6 dB increase in phase noise (for offsets greater than 1 kHz), the phase noise of the HP 8662A/8663A output in the doubled bands should be about 6 and 12 dB higher than that in the main band. Likewise, the phase noise in the divide-by-2 and divide-by-4 bands should be about 6 and 12 dB lower. The phase noise in the heterodyne band should be about the same as in the main band, except that some noise cancellation occurs close to the carrier due to cancellation of correlated reference section noise in the down conversion process. Similarly, in divide bands, maximum FM deviation is reduced by the divide number, in the multiply bands it is increased by the multiply number, and in the heterodyne band, it remains the same as in the fundamental band.

The actual residual phase noise over the entire frequency range of the HP 8662A and 8663A is shown in Table 3.2. For each divide-by-2 or multiply-by-2 from the main band frequency, the phase noise decreases or increases by 6 dB, respectively. Note how closely the actual correlates with the expected values. This close correlation results from careful design in all parts of the output section. Areas of particular concern included designing the AGC loop for minimum AM-to-PM noise conversion and obtaining carefully controlled levels at the inputs to the heterodyne band mixer. The resulting broadband noise floor of the HP 8662A/8663A is less than -148 dBc at offsets greater than 1 MHz.

Table 3.2. Typical HP 8662A/8663A residual SSB phase noise.

Offset from Carrier	Carrier Frequency					
	Heterodyne	÷4	÷2	Main-band	×2	×4
	0.01 to 120 MHz	120 to 160 MHz	160 to 320 MHz	320 to 640 MHz	640 to 1280 MHz	1280 to 2560 MHz*
10 Hz	-113	-119	-113	-107	-101	-95
100 Hz	-126	-129	-124	-119	-111	-106
1 kHz	-133	-138	-133	-128	-122	-116
10 kHz	-137	-147	-142	-136	-130	-124
100 kHz	-134	-145	-142	-136	-130	-124

*HP 8663A only.

Chapter 4

Improving Frequency Stability with External References

A synthesizer is defined as a signal source in which all output frequencies are derived from a single fixed-frequency reference oscillator, where the long- and short-term stability of the reference is translated to the output. This chapter examines how the stability of the reference oscillator affects the stability of the output frequency of the HP 8662A/8663A. The first part of the chapter shows how the long and short-term stability of the HP 8662A/8663A's own internal reference are translated to the output signal. The chapter then describes a specific case of using a cesium beam as an external reference to improve both the close-in short-term stability as well as the long-term stability of the HP 8662A/8663A. This specific case is then expanded to discuss the effect of an arbitrary external reference on the stability parameters of the HP 8662A/8663A.

Why Use an External Reference?

The internal reference in the HP 8662A/8663A is a 10 MHz crystal oscillator. The absolute phase noise and long-term frequency stability of the HP 8662A/8663A apply only with this internal reference. Often, however, an external reference is used. (The HP 8662A/8663A accepts any external 5 MHz standard at a level of $1 V_{\text{rms}} \pm 0.1 V$ or any 10 MHz reference at a level of 0.5 to $0.7 V_{\text{rms}}$ into 50 ohms.) For example, in a system it is often desirable to operate all the components of the system from a common reference. If another reference in the system is chosen as the common reference, the long- and short-term stability of the HP 8662A/8663A will be altered. Since the use of an external reference does alter these frequency stability parameters, an external reference can be used to improve them.

Reference Effects on Long-Term Stability

Frequency stability can be defined as the degree to which the oscillating source produces the same frequency throughout a specified period of time. This definition of frequency stability includes the concepts of random noise, residual and incidental modulation, and any other fluctuations of the output frequency.

Long-term stability, often called frequency drift, refers to the change in output frequency over a period of time usually greater than a few seconds. For

synthesizers, it is commonly expressed in fractional parts of a cycle per day, week, month, or year. Long-term stability usually results from aging of the components and materials used in the oscillating source.

For the HP 8662A/8663A, the relationship between the long-term stability of the reference and the long-term stability of the output frequency is simple. Because of the nature of the synthesis process, the frequency drift and accuracy of the output signal is equal to that of the reference, whether it is internal or external.

The internal reference in the HP 8662A/8663A is an oven-controlled crystal oscillator with specified long-term stability of 5×10^{-10} per day after a 10-day warmup. The frequency accuracy is a function of time base calibration, aging rate, temperature effects, and line voltage effects. These parameters are directly translated to the HP 8662A/8663A output frequency.

If an external reference is used, the HP 8662A/8663A long-term stability can be either degraded or improved. Typical long-term stability for room temperature crystal oscillators is 1×10^{-6} per month. A secondary standard such as a rubidium oscillator has long-term stability on the order of 1×10^{-11} per month. Primary frequency standards such as cesium beams have even less frequency drift—specifying stability on the order of 5 parts in 10^{-12} for the life of the cesium beam tube.

Effect of the Reference on Short-Term Stability

A common measure of short-term frequency stability is single-sideband (SSB) phase noise; see Chapter 2 for a discussion of phase noise and its implications. In a synthesizer, two types of phase noise are usually specified—residual and absolute. Residual phase noise is the phase noise inherent in the synthesizer; that is, it is a theoretical limit on the noise performance of the synthesizer. The noise on the output signal can never be better than the residual noise.

Absolute or total noise is the total phase noise present at the device output. Absolute noise includes the noise contribution of the reference used, and will change with different references.

To examine how the noise on the reference oscillator translates to or affects the absolute noise of the HP 8662A/8663A, consider the plot of typical HP 8662A/8663A absolute and residual SSB phase noise (Figure 4.1). Note that the absolute noise with the internal reference is greater than the residual noise only for offsets from the carrier less than about 2 kHz. For offsets greater than 2 kHz, the residual noise is the same as the absolute noise. The internal reference in the HP 8662A/8663A has typical phase noise as shown in Table 4.1. This phase noise at 10 MHz is translated to the equivalent phase noise at a carrier frequency of 500 MHz and is plotted on the same graph with the typical phase noise of the HP 8662A/8663A in Figure 4.1.

Offset from Signal f	Phase Noise Ratio $\mathcal{L}(f)$
1 Hz	-90 dBc
10 Hz	-120 dBc
100 Hz	-140 dBc
1 kHz	-157 dBc
10 kHz	-160 dBc

Table 4.1.
HP 8662A/8663A internal reference oscillator phase noise.

The graph shows that the absolute phase noise of the HP 8662A/8663A closely follows the translated noise of the reference to about 2 kHz offset from the carrier. Beyond 2 kHz offset, the noise on the reference oscillator remains flat, while the absolute noise of the HP 8662A/8663A continues to drop until it reaches the residual noise level. For offsets greater than about 2 kHz, the typical phase noise of the reference oscillator is actually greater than the typical absolute noise of the HP 8662A/8663A.

would be about -124 dBc at a 100 kHz offset. The filters, however, effect substantial noise reduction, with about 35 dB of noise attenuation, to reduce the broadband noise floor to about -160 dBc. In addition to the noise reduction effected by the crystal filters, the bandwidths of the phase-locked loops were carefully chosen to minimize broadband noise. However, most of the noise reduction is due to the filtering. For more information on the design of the HP 8662A/8663A and the reference section, see Chapter 3.

HP 8662A/8663A Stability Using a Cesium-Beam Reference

An excellent external reference source for improving the long-term stability of the HP 8662A/8663A is a cesium beam frequency standard. To see how the noise of a cesium standard affects the short-term stability or absolute noise of the HP 8662A/8663A, and to expand that to the general effect of using an external reference, this section examines the measured absolute noise performance of the HP 8662A/8663A with the Hewlett-Packard Model 5061A Cesium Beam Frequency Standard (with high stability Option 004 for improved phase noise) as an external reference.

A good insight into the expected noise performance of the HP 8662A/8663A with the cesium-beam standard as an external reference can be gained by comparing the specified single-sideband phase noise of the HP 5061A to that of the HP 8662A/8663A 10 MHz internal reference. Figure 4.2 plots these noise characteristics, with the noise of the 5 MHz HP 5061A converted up to the equivalent noise at 10 MHz.

The phase noise of the HP 8662A/8663A internal reference is graphed with a dashed line for offsets from the carrier less than 1 Hz because the phase noise is actually specified only for offsets greater than 1 Hz. Phase noise information at offsets greater than 1 Hz is normally sufficient for those applications where a crystal would be used. However, the time domain stability (fractional-frequency deviation) for averaging times from τ equal to 10^{-3} to 10^2 seconds is specified for the HP 8662A/8663A reference oscillator. These time-domain representations of short-term stability were translated to equivalent frequency-domain representations for offsets less than 1 Hz by algebraic calculations accepted by the U.S. National Bureau of Standards (NBS). For more information on how to perform these translations, see NBS Technical Note 679, "Frequency Domain Stability Measurements: A Tutorial Introduction."

Figure 4.2 shows that the phase noise of the HP 5061A Cesium Beam is greater than that of the HP 8662A/8663A reference oscillator for offsets from the carrier greater than approximately 2 Hz. Since the bandwidth of the first crystal filter in the HP 8662A/8663A reference section at 40 MHz is

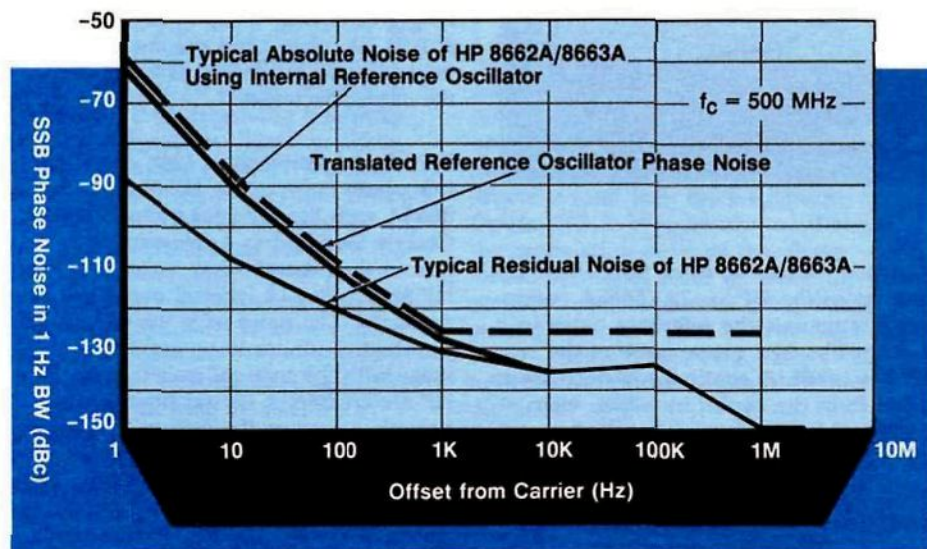

Figure 4.1. Comparison of HP 8662A/8663A noise vs. noise of internal reference.

The reference section of the HP 8662A/8663A was designed to ensure that this high reference noise at offsets greater than 2 kHz would not contribute to the absolute noise of the output signal; that is, the reference section includes filters to improve the broadband noise performance over the noise of the internal reference. In the reference section, the 10 MHz reference signal is directly multiplied up to 640 MHz for use in other parts of the HP 8662A/8663A.

Were nothing else done to this 640 MHz signal, the broadband noise would be translated to the output frequency. However, to improve the broadband noise, monolithic crystal filters were added in the reference multiplier chain at 40 and 160 MHz. The 40 MHz filter has a bandwidth of about 6 kHz; the 160 MHz filter a bandwidth of about 18 kHz. With no filtering, the noise floor on the multiplied-up reference signal (640 MHz)

In summary, due to the design and filtering of the reference section, the noise of the reference oscillator primarily affects the close-in absolute phase noise of the HP 8662A/8663A. Up to about 2 kHz, the dominant noise mechanism is that of the multiplied-up reference section. Beyond 2 kHz, the crystal filters in the reference multiplier chain filter the reference oscillator noise and the broadband noise floor reaches the HP 8662A/8663A residual noise level. Absolute noise can be improved by using a lower-noise reference. Again, by the definition of residual noise, no external reference, no matter how low in noise, could reduce the absolute noise of the HP 8662A/8663A to anything less than the residual noise. If the noise of the external reference is actually lower than the residual noise of the HP 8662A/8663A, the HP 8662A/8663A's residual noise would dominate.

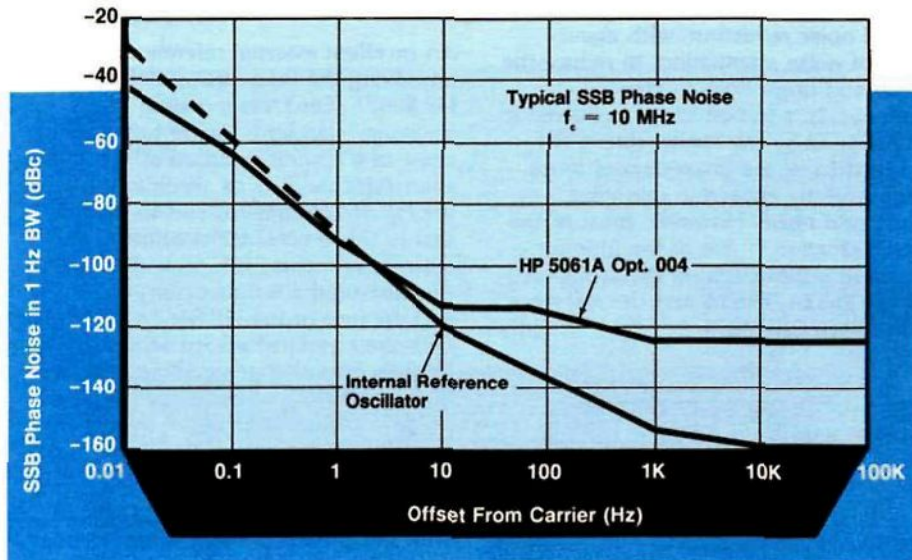

Figure 4.2. Noise comparison of internal reference oscillator vs. HP 5061A cesium beam.

approximately 6 kHz, attenuation of this higher noise would not start until about 4 kHz from the carrier. Therefore, the absolute noise of the HP 8662A/8663A with the HP 5061A as an external reference is higher than the absolute noise with the internal reference at offsets greater than 2 Hz. But because of the filtering and effect of loop bandwidths in the HP 8662A/8663A, this higher reference noise is eventually attenuated until the residual noise is dominant.

Figure 4.3 shows the absolute phase noise results; the absolute phase noise of the HP 8662A/8663A with the HP 5061A Option 004 Cesium Standard is shown for offsets from 0.1 Hz to 100 kHz. To examine the relationship between the noise of the reference and the resultant absolute noise of the HP 8662A/8663A, the specified phase noise of the cesium standard converted to the equivalent noise at 500 MHz is also plotted. As in the case of the internal reference, close to the carrier (here for offsets less than 10 Hz) the absolute phase noise of the HP 8662A/8663A very closely follows the noise spectrum of the reference used. Between 10 Hz and 1 kHz, the absolute phase noise of the HP 8662A/8663A generally follows the noise curve of the cesium reference, except that the noise "plateau" of the cesium is smoothed out by filtering. For offsets greater than 1 kHz, the cesium

standard reaches its noise floor. Here the filtering in the HP 8662A/8663A continues to attenuate the reference noise so that the absolute phase noise of the HP 8662/8663A continues to decrease as offset from the carrier increases, even though the reference has reached its broadband noise floor.

To show the advantages and disadvantages of using a cesium beam as an external reference, Figure 4.4 compares the measured absolute noise of the

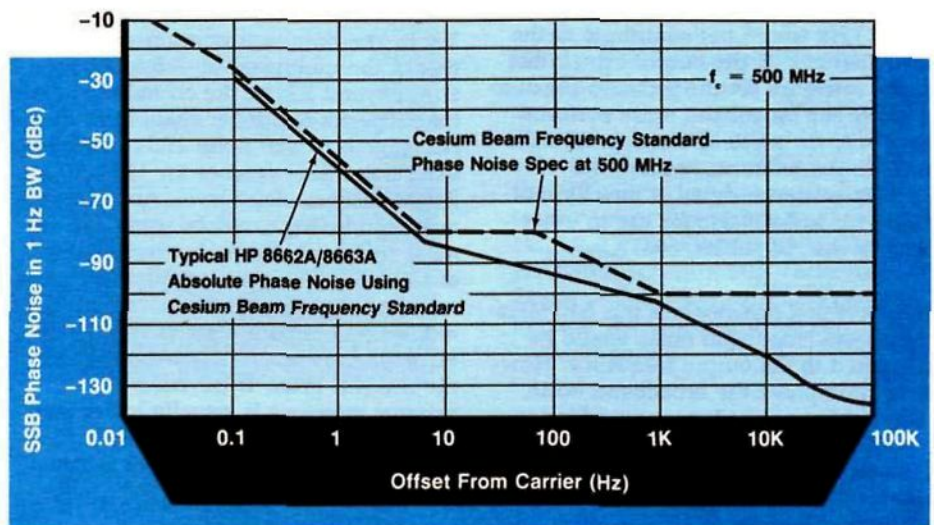

Figure 4.3. Effect of cesium beam frequency standard on HP 8662A/8663A absolute noise.

HP 8662A/8663A with its own internal crystal reference, the absolute noise with the cesium frequency standard, and the typical residual phase noise of the HP 8662A/8663A. Figure 4.2 shows that the noise of the cesium standard is lower than the noise of the internal crystal oscillator for offsets less than about 2 Hz. As expected, this same relationship is translated to the absolute phase noise of the HP 8662A/8663A when these two references are used. The very close-in phase noise (less than 1 Hz offset) of the HP 8662A/8663A is improved with use of the HP 5061A Option 004 Cesium Standard as an external reference, exhibiting greater than 10 dB of improvement at 0.01 Hz offset, with the amount of improvement increasing as offset from the carrier decreases.

For offsets greater than 2 Hz, the absolute phase noise of the HP 8662A/8663A with the HP 5061A Option 004 Cesium Standard as a reference is greater than the absolute noise with the HP 8662A/8663A internal oscillator, as predicted. The noise with the cesium standard continues to be higher than the noise with the internal crystal until the HP 8662A/8663A crystal filters can sufficiently attenuate the cesium's higher reference-noise floor to less than the residual noise. Figure 4.4 shows that this reduction occurs at an offset from the carrier of around 25 kHz. This is consistent with the fact that the second crystal filter at 160 MHz has a bandwidth of approximately 18 kHz.

In summary, Figure 4.4 shows that use of an HP 5061A Option 004 Cesium Beam optimizes the very close-in phase noise (less than 1 Hz) of the HP 8662A/8663A. For some applications, this very close-in phase noise is critical. However, if offsets from the carrier from 1 Hz to 100 kHz are of more concern, as in many types of receiver testing, use of the HP 8662A/8663A internal crystal reference provides better performance.

Effect of an Arbitrary Reference

Expanding the results to the general case of any external reference, the close-in phase noise of the reference is translated to the absolute noise of the HP 8662A/8663A output frequency, whether the noise of the external reference is higher or lower than that of the internal crystal oscillator. At greater offsets from the carrier, if the external reference has higher noise than the internal reference, this noise will also be seen as absolute noise, until the HP 8662A/8663A filtering can reduce the reference noise to less than the residual noise. This should normally occur at an offset around 20 to 30 kHz. However, if the reference noise is extremely high, this might occur at a higher offset from the carrier as a function of the frequency response of the crystal filters.

For the lowest phase noise at all offsets from the carrier, a combination of the absolute noise of the cesium standard at offsets less than 1 Hz and the absolute

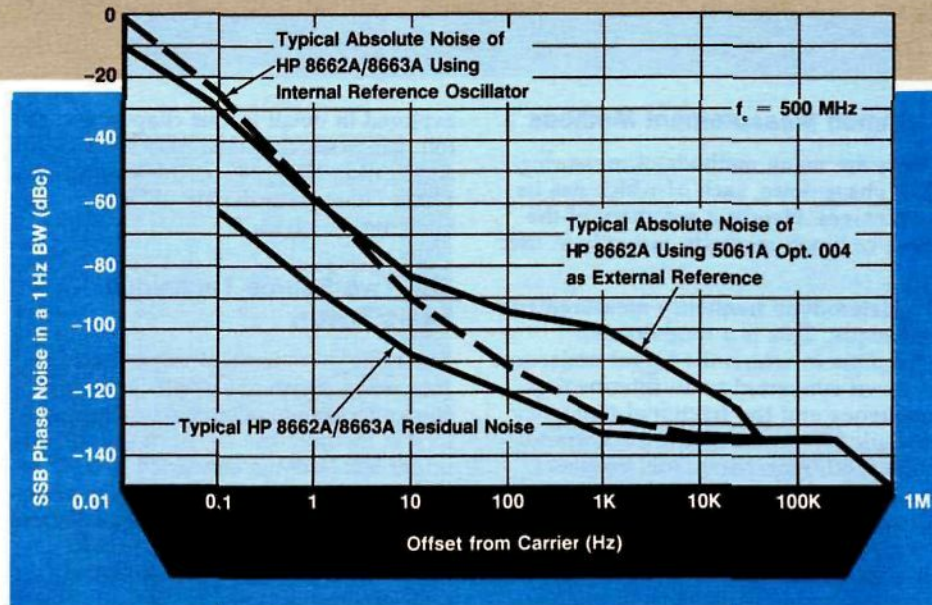

Figure 4.4. HP 8662A/8663A absolute noise comparison.

noise of the internal oscillator, or some other crystal reference, at offsets greater than 1 Hz would be optimal. This optimal solution is technically feasible. One solution is shown in Figure 4.5.

The "lock box" is basically just an external phase-locked loop with the cesium standard acting as the reference oscillator and the crystal oscillator as the voltage-controlled oscillator (VCO). Figure 4.6 shows the lock box in simple block-diagram form.

The phase-locked loop locks the crystal VCO to the cesium standard in less than

1 Hz bandwidth. Within the bandwidth of the loop, the noise at the output of the VCO is equal to the noise on the reference. But outside the bandwidth of the loop, the loop no longer tracks the reference, and the noise of the VCO will be translated to the output.

This "lock box" is commercially available as Hewlett-Packard Model 5061A K34-59991A, with a bandwidth of approximately 0.16 Hz. It can be directly connected to the HP 8662A/8663A external-frequency-control input.

This arrangement yields the excellent very close-in phase noise of the HP 5061A Option 004 Cesium Beam Frequency Standard, the low phase noise of the HP 8662A/8663A internal reference oscillator at offsets from 1 Hz to 100 kHz, the low broadband noise floor of the HP 8662A/8663A and the outstanding long-term frequency stability of the cesium beam $\pm 3 \times 10^{-12}$ for the life of the cesium beam tube.

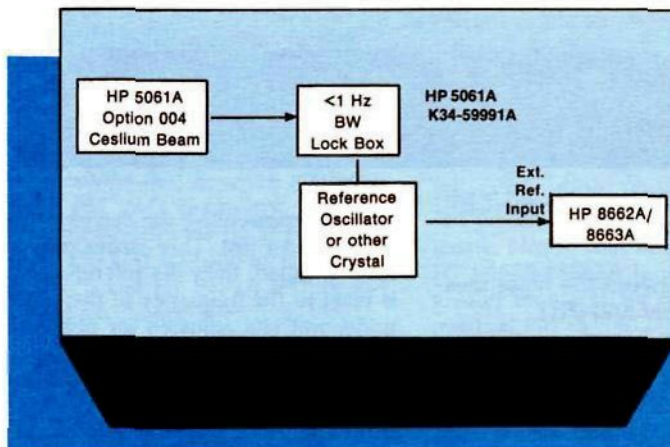

Figure 4.5. Using two references for optimal HP 8662A/8663A phase noise.

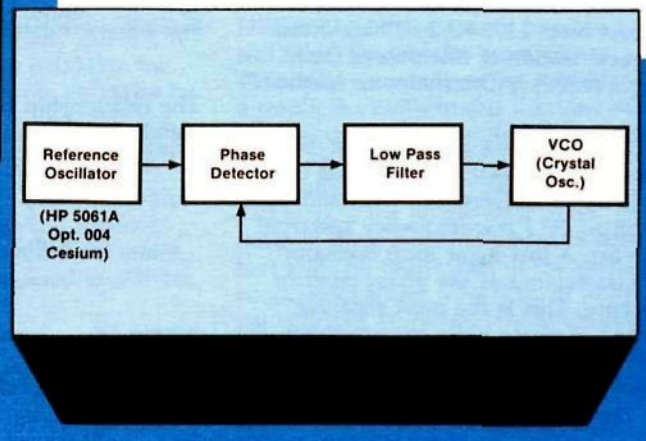

Figure 4.6. Narrowband phase-locked loop for two-reference system.

Chapter 5

SSB Phase Noise Measurement

Common Measurement Methods

There are many methods of measuring SSB phase noise, each of which has its advantages. Here is a summary of the most common methods currently in use:

1. Heterodyne frequency measurement technique. This is a time-domain technique in which the signal under test is down converted to an intermediate frequency and the fractional frequency deviation is measured using a computer-controlled, high-resolution frequency counter. $\sigma(\tau)$ is then calculated (see Chapter 2), and the computer transforms the time domain information to equivalent values of SSB phase noise. This method is particularly useful for phase noise measurements at offsets less than 100 Hz.

2. Direct measurement with a spectrum analyzer. This is the frequency-domain technique discussed briefly in Chapter 2. This method is limited by the spectrum analyzer's dynamic range, selectivity, and LO phase noise. For more information, see Hewlett-Packard Application Note 270-2, "Automated Noise Sideband Measurements Using the HP 8568A Spectrum Analyzer."

3. Measurement with a frequency discriminator. In this frequency-domain method, the signal under test is fed into a frequency discriminator and the output of the discriminator is monitored on a low-frequency spectrum analyzer. The best performance is obtained with a delay line/mixer combination as discriminator. Due to the inherent relationship between frequency modulation and $S_{\phi}(f)$, the noise floor of this kind of system rises rapidly for small offsets. The resulting higher noise floor limits the usefulness of this method for these small carrier offsets. Reference HP Product Note 11729C-2, "Phase Noise Characterization of Microwave Oscillators Frequency Discriminator Method."

4. The two-source technique. In this phase detector method, the signal under test is down converted to 0 Hz and examined on a low-frequency spectrum analyzer. A low-noise local oscillator (LO) is required as the phase detector reference. This is the most sensitive method of phase noise measurement. For this reason, and because the HP 8662A/8663A is ideally suited as the low-noise LO, the phase detector method is

explored in detail in this chapter and the following two chapters. Also see HP Application Note 246-2, "Measuring Phase Noise with the HP 3585A Spectrum Analyzer."

The Two-Source Technique Basic Theory

The basic measurement setup used for measuring phase noise with the two-source technique is shown in Figure 5.1. In this method, the signal of the source under test is down converted to 0 Hz or dc by mixing with a reference signal of the same frequency in a double-balanced mixer. The reference signal is set in phase quadrature (90 degrees out of phase) with the signal under test. When this condition of phase quadrature is met, the mixer acts as a phase detector, and the output of the mixer is proportional to the fluctuating phase difference between the inputs. Hence the SSB phase noise characteristics may be determined by examining the mixer output signal on a low frequency spectrum analyzer. The frequency of the noise displayed by the analyzer is equal to the offset from the carrier.

$$(V_{brms}, \text{ where } V_{brms} = \frac{V_{bpeak}}{\sqrt{2}})$$

produced in the calibration is described below. This assumes a sinusoidal beat note and a linearly operating mixer.

$$S_{\phi}(f) = \frac{V_{rms}^2}{(V_{bpeak})^2} \quad (\text{in a 1 Hz bandwidth})$$

$$= \frac{V_{rms}^2}{2(V_{brms})^2} \quad (\text{in a 1 Hz bandwidth})$$

$$\mathcal{L}(f) = \frac{S_{\phi}(f)}{2} = \frac{V_{rms}^2}{4(V_{brms})^2} \quad (\text{in a 1 Hz bandwidth})$$

This relationship reveals how to calibrate the measurement to obtain $\mathcal{L}(f)$. First the reference source is offset by a small amount such as 10 kHz to produce a beat note from the mixer that can be measured on the spectrum analyzer (V_{brms}). This beat note can be consid-

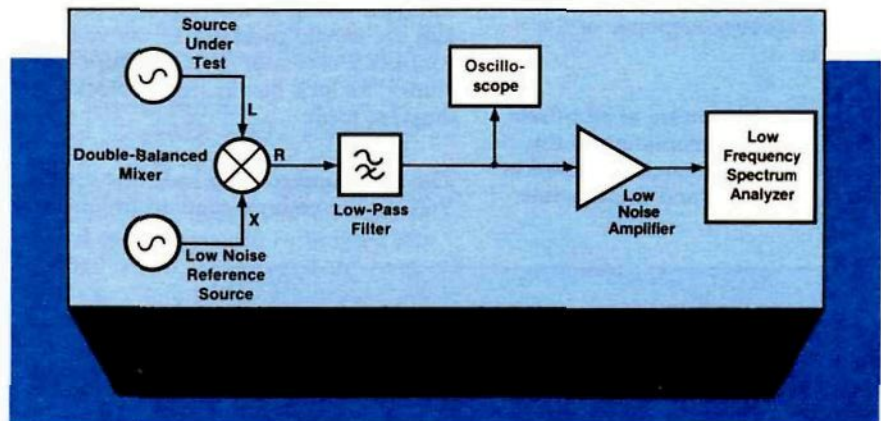

Figure 5.1. Basic two-source phase noise measurement setup.

The relationship between the noise measured on the analyzer and $\mathcal{L}(f)$ (Chapter 2) is derived from

$$\Delta\phi_{rms} = \frac{V_{rms}}{K_{\phi}}$$

where $\Delta\phi_{rms}$ = rms phase deviation of phase noise, V_{rms} = noise level measured on spectrum analyzer, and K_{ϕ} = phase detector constant which is V_{bpeak} . The level of the beat note

is considered as representing the carrier of the signal under test. This carrier reference level is noted, then the reference source is reset to the frequency of the source under test and adjusted for phase quadrature. Quadrature is indicated by zero volts dc as monitored on the oscilloscope. The noise displayed on the spectrum analyzer corresponds to phase noise and the spectrum analyzer's frequency scale corresponds to the carrier offset frequency. To make an SSB phase noise measurement, the level of the noise on the spectrum analyzer is measured referenced to the carrier level noted above (V_{brms}). The actual SSB

phase noise level is 6dB below this reading because of the factor of $\frac{1}{4}$ in the last equation above.

There are two other methods used to calibrate the two-source measurement. One generates a very low-level sideband by angle modulating one of the two sources at a low level. The other generates a very low-level sideband by summing in a discrete low-level signal. If the level of the sideband relative to the carrier is accurately known, the sideband can be used to indicate a reference level. The phase-noise level can then be measured relative to the sideband reference level. When angle modulating one of the sources no correction factor is required, when summing in a discrete signal the 6 dB correction mentioned previously is needed. For example, if the sideband is set to -40 dBc and the noise level is 50 dB below the sideband, the SSB phase noise level is -90 dBc/Hz when calibrating using angle modulation. When summing in a discrete signal, the SSB phase noise level is -96 dBc/Hz for the same reference levels.

The noise measured by the two-source technique described above represents the combined noise of both the source under test and the reference source. This is the upper limit for the phase noise of either device, however, if the phase noise of one of the two sources is known accurately the phase noise of the other source can be determined. Since the phase noise of the HP 8662A/8663A is well characterized it is an excellent choice as a reference source. The error introduced by the finite noise contribution of the reference is given by:

$$\text{Error (dB)} = 10 \text{ LOG} (1 + P_{\text{ref}}/P_{\text{dut}})$$

where

P_{ref} = Actual Noise Power of the Reference Source

P_{dut} = Actual Noise Power of the Source Under Test

and Error is defined as

$$\mathcal{L}(f)_{\text{MEASURED}} \text{ (in dB)} = \mathcal{L}(f)_{\text{ACTUAL}} \text{ (in dB)}$$

This equation indicates that it is desirable to use a reference source with the lowest possible noise. For example, if it is known that the reference has about one-tenth as much noise as the source under test, the noise measured using the

two-source technique will be within 0.5 dB of the actual noise of the source under test.

If the source under test has phase noise within 10 dB of the reference the actual phase noise of the source can be accurately determined if three unknown sources are available. Three measurements with three different source combinations yield sufficient data to calculate accurately the noise of each source. Appendix A gives formulas for this calculation.

Because phase noise is usually specified in a 1 Hz bandwidth, the result obtained from the above measurement must also be corrected for the equivalent noise bandwidth of the spectrum analyzer. This bandwidth normalization process simply requires subtracting $10 \log$ (equivalent noise bandwidth in Hz) from the measured value. For example, if a value of -123 dBc is obtained from a measurement with a spectrum analyzer equivalent noise bandwidth of 1.2 kHz, this value must be corrected by subtracting $10 \log (1200)$, yielding -153.8 dBc/Hz. Most Hewlett-Packard RF spectrum analyzers have equivalent noise bandwidths of approximately 1.2 times the

measured using a synthesized signal generator as a calibrated source.

In addition to the 6 dB, and bandwidth normalization correction factors explained above, other correction factors may be required, depending on the type of spectrum analyzer used. Most analog spectrum analyzers use logarithmic amplifiers and peak detectors. The log amplifier amplifies peaks less than the rest of the noise signal. In addition, even though the spectrum analyzer is calibrated to read rms values, the peak detector tends to produce a reading that is lower than the true rms value when responding to random noise. Due to these effects, the resulting value of noise measured on the spectrum analyzer is about 2.5 dB less than the actual noise level. Thus a correction factor of 2.5 dB must be added to the measured value to compensate for log amplification and peak detection. For further explanation of spectrum analyzer corrections, refer to Hewlett-Packard Application Note 150-4, "Spectrum Analysis . . . Noise Measurements."

The Importance of Quadrature

The two-source technique explained above may be applied directly if both

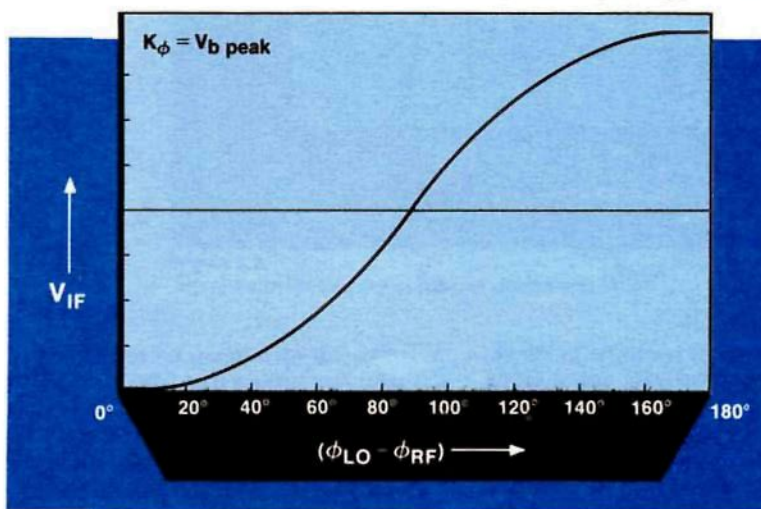

Figure 5.2. Typical double-balanced mixer phase detector characteristic.

3 dB bandwidth of the analyzer. Note that the 3 dB bandwidth of the analyzer is not necessarily equal to the front-panel resolution bandwidth setting, since the front-panel setting is a nominal figure. For best accuracy, the 3 dB bandwidth of the analyzer used should be

sources have sufficient long-term phase stability to stay in phase quadrature during the measurement. The importance of quadrature is illustrated by the typical phase detector characteristic curve of a double-balanced mixer shown in Figure 5.2. The curve shows that the point of maximum phase sensitivity and the center of the region of linear opera-

tion occur where the phase difference between the two inputs ($\phi_{LO} - \phi_{RF}$) is equal to 90 degrees (phase quadrature). Any deviation from quadrature results in a measurement error given by:

$$\text{error(dB)} = 20 \log [\cos(\text{magnitude of phase deviation from quadrature})]$$

where error is defined as $\mathcal{L}(f)_{\text{measured}}$ in dB minus $\mathcal{L}(f)_{\text{actual}}$ in dB. Note that the error in dB is always negative, that is, the measured noise will always be less than the actual noise.

Since the phase detector constant K_ϕ can be measured ($K_\phi = V_{\text{bpeak}}$), for a given acceptable measurement error the permissible deviation from zero volts dc of the average mixer output voltage can be calculated using the phase detector characteristic curve. This is given by:

deviation from zero volts dc =

$$K_\phi \sqrt{1 - 10^{\text{error (dB/5)}}$$

As an example, suppose K_ϕ has been measured to be 0.15 volts/radian. If it is desired to keep the measurement error due to deviation from quadrature less than -0.5 dB, the oscilloscope should be monitored during the phase noise measurement to ensure that the average mixer output voltage is within the range of ± 68 millivolts.

The quadrature condition represents not only the point of maximum phase sensitivity but also the point of minimum AM noise sensitivity. As the two mixer inputs drift out of quadrature and the phase noise sensitivity decreases, the AM noise sensitivity of the mixer increases. Such increased sensitivity to AM noise may cause an additional measurement error if the source under test has high AM noise.

Phase-Locked Measurements

If the two sources cannot stay sufficiently close to quadrature during the phase noise measurement, a "phase-locked" measurement must be made. This involves phase-locking one of the sources to the other by connecting the mixer output to a frequency control line on one of the sources. This causes that source to track the other source in phase. Thus, if the two sources have been set in phase quadrature, they will remain in quadrature. The bandwidth of the phase-locked loop must be set much lower than the lowest offset at which phase noise is to be measured. This is necessary because the tracking of phase-locked loops attenuates phase noise within the loop bandwidth, and this attenuation causes the phase noise to appear lower than it actually is. An example of a phase-locked phase-noise measurement is discussed in Chapter 6. Alternatively, if it is not possible to make the bandwidth smaller than the offsets of interest, a correction must be made for the attenuation of the noise sidebands by the action of the loop.

Chapter 6

Measuring SSB Phase Noise with the HP 8662A/8663A

The extremely-low SSB phase noise and excellent long-term stability of the HP 8662A/8663A allow them to serve in many cases as the low-noise reference source required in the two-source technique, as discussed in Chapter 5. The following sections describe the use of the HP 8662A/8663A in measuring SSB phase noise and extends these techniques to include automation via the Hewlett-Packard Interface Bus (HP-IB). Chapter 7 discusses the use of the HP 8662A/8663A as a low-noise reference multiplied up to microwave frequencies for phase-noise measurement of microwave sources.

SSB Phase-Noise Measurements on Sources Operating from a Common Reference

An HP 8662A/8663A-based system for measuring the SSB phase noise of sources that operate from a 5 or 10 MHz reference oscillator is shown in Figure 6.1. Note that the system uses the basic two-source technique, except that the frequency reference for the device under test, a synthesizer in this example, is the 10 MHz rear-panel reference output of the HP 8662A/8663A. A 5 or 10 MHz external reference oscillator could also be used. Since both sources have the same reference, they remain in phase quadrature once quadrature is set, provided that the source under test has adequate phase stability. A second method for locking an HP 8662A/8663A in quadrature to a free running source is discussed in this chapter under the heading Phase-Locked Measurements Using the HP 8662A/8663A DC FM Mode.

When making a phase-noise measurement with the system in Figure 6.1, it is important to note that any phase noise on the output of the synthesizer under test which is correlated with the noise at the HP 8662A/8663A output will be cancelled in the double balanced mixer. That portion of the reference-oscillator noise that is present at the outputs of both sources correlates if the total signal paths through the two sources introduce the same time delay. Thus, under these conditions, the common reference oscillator noise cancels and the noise measured by the system is equal to the residual noise of the source under test after correction factors for the HP 8662A/8663A residual noise contribution are applied. Due to the crystal filtering in the reference section of the HP 8662A/8663A, the absolute HP 8662A/8663A noise is correlated to its reference only at carrier offsets less than about 3 kHz.

Thus, this system is limited to residual phase noise measurements at offsets less than 5 kHz and then only if the time delays through the HP 8662A/8663A and the synthesizer under test are equal. At offsets greater than this, or at offsets greater than the loop bandwidth of the device under test, whichever is greater, the noise measured by the system is the absolute noise of the synthesizer under test.

The HP 8662A/8663A 10 MHz reference output supplies greater than 0.5 V_{rms} into 50 ohms. If this is insufficient to drive the synthesizer under test, additional amplification may be added pro-

vided care is taken to ensure that the amplifier does not add to the reference oscillator's noise level. A typical 10 MHz amplifier circuit that will give good results is shown in Appendix B. This circuit is similar to that used in the HP 8662A/8663A reference section.

COMPONENT CONSIDERATIONS

Because the components in the system of Figure 6.1 are important in determining the system's measurement limits, they are discussed in detail below.

The Phase Detector

Any double-balanced mixer specified for operation at the frequency of the synthesizer under test will serve as a phase detector. The IF output port of the mixer must be DC coupled to make measurements very close to the carrier. Mixers specified for higher power levels provide more sensitivity by accommodating higher carrier levels and thus increased carrier-to-noise floor ratios. Linear mixer operation is especially important to avoid errors during system calibration. (To avoid operating in the non-linear region of the mixer, input power levels can be reduced at the cost of reduced sensitivity.) Several excellent mixers for this purpose are available from commercial sources. This system uses a Hewlett-Packard Model 10514A for measurements up to 500 MHz.

The Low-Pass Filter

The low-pass filter prevents LO feed-through and mixer sum products from overloading the low-noise amplifier or the input of the spectrum analyzer. In theory, any general-purpose low-pass network with a cutoff frequency sufficiently above the highest offset frequency of interest may be used. However, many passive filters terminate the mixer in a reactive load at RF frequencies. As a result, the mixer sum products are reflected back into the mixer, causing distortion of the phase slope. To avoid this, the low-pass filter should be preceded by a simple decoupling network that terminates the mixer in 50 ohms at the sum product frequency (twice the carrier frequency of the signal under test).

Figure 6.2 shows an example of a two-pole, low-pass filter that correctly terminates the mixer sum frequencies above 10 MHz, yet unloads the mixer at the lower frequencies where the noise volt-

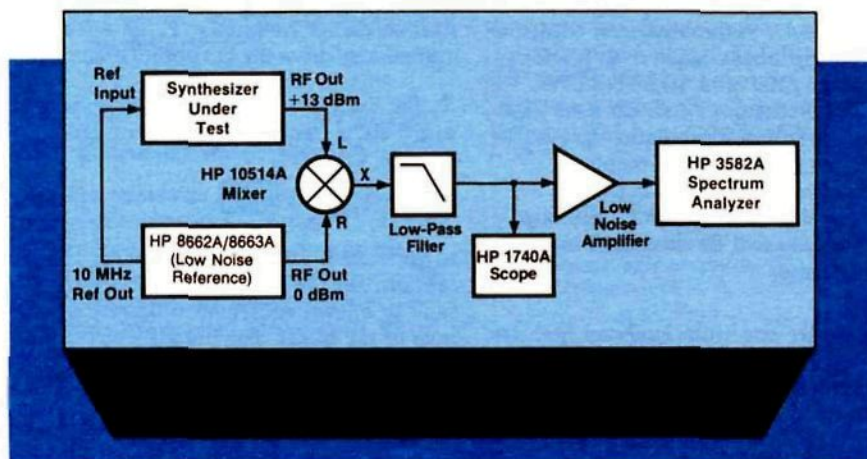

Figure 6.1. Measuring phase noise on sources with a common reference.

age fluctuations of interest occur. R1 and C1 terminate the mixer properly. R2 and C3 provide a decoupled means of monitoring quadrature on the oscilloscope without introducing further noise. The values given for L1 and C2 set a 90 kHz cutoff.

not introduced into the measurement. The linear input range should be approximately 30 to 50 dB below the carrier level for unattenuated beat note calibration. The reasons for this constraint are made clear by the system calibration explanation in the following

- bandwidth normalization allowing noise levels to be read directly in dBV/Hz.
- relative amplitude values presented directly in dB.
- digital display with alphanumeric readout of spans, marker frequency, and marker amplitude.

An additional feature of the HP 3582A is its high speed. It is well suited for low frequency, close-in measurements. The HP 3585A provides measurements at wide offsets.

MEASUREMENT PROCEDURE

The manual measurement discussed in this section uses the HP 3582A Spectrum Analyzer because of its speed in swept close-in measurements. The automated SSB measurements which follow demonstrate the efficiency of the HP 3585A Spectrum Analyzer for automated spot measurements at predetermined offsets.

Calibration

The system is easily calibrated by offsetting one of the sources and observing the resultant beat signal on an oscilloscope or spectrum analyzer. As discussed in Chapter 5, the slope at the zero crossing in volts per radian is K_ϕ and for sinusoidal beat signals is equal to the peak voltage of the signal (V_{bpeak}). The beat signal as viewed on an analyzer is the rms value and so is 3 dB less than the peak.

In order to determine the beat signal zero crossing slope in volts per radian:

- Set the synthesizer under test to the desired carrier frequency, F_c , at a level sufficient to drive the LO port of the mixer.
- Set the HP 8662A/8663A frequency to F_c . Set a frequency increment of 10 kHz. Press



to generate a 10 kHz beat note for calibration. Set the HP 8662A/8663A amplitude to a level sufficient to drive the RF port of the mixer. For the HP 10514A, the LO should be +10 dBm and the RF 0 dBm. Set an amplitude increment of 40 dB. Press



The attenuation is added to ensure that the low noise amplifier will not be over-

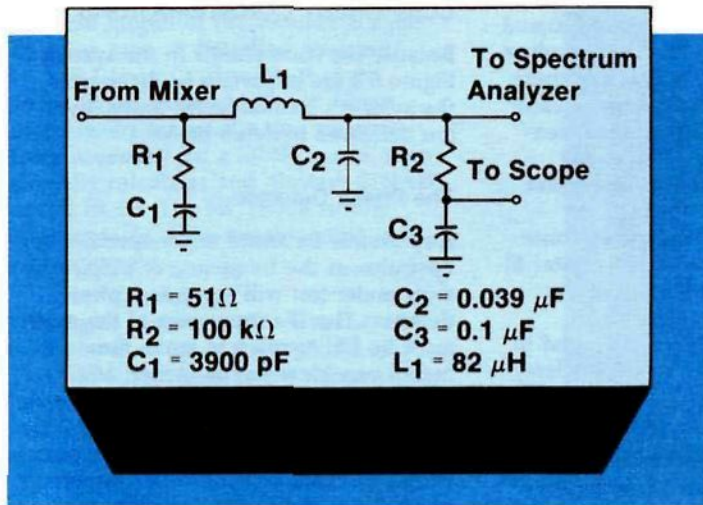

Figure 6.2. Low-pass filter for two-source measurement

The Quadrature Monitor

Any general-purpose, dc-coupled oscilloscope will do for determining the phase detector constant K_ϕ (volts/radian) as discussed in chapter 5, and for setting and monitoring quadrature. The Hewlett-Packard 1745A works well for this purpose. Although a dc voltmeter can be used to set and monitor quadrature, an oscilloscope is much more useful for time domain inspection of the phase noise signal. Digital voltmeters have the added disadvantage of introducing noise in very sensitive measurements.

The Low-noise Amplifier

The low-noise amplifier (LNA) improves the sensitivity and noise figure of the spectrum analyzer. The requirements of this amplifier are determined by the levels of phase noise to be measured and the dynamic range of the spectrum analyzer. In some instances, the LNA may not be required. However, critical low-noise measurements call for this additional amplification. In general, the amplifier should have a low-frequency cutoff well below the lowest offset frequency to be measured. Consideration must also be given to the noise floor and 1/f noise of the amplifier so that additional noise is

section. A circuit for a typical low noise amplifier that meets these requirements is shown in Appendix C. If the device used (2N6428) is hand selected for low 1/f noise, noise figures as low as 10 dB at 10 Hz may be achieved. This is the LNA used in the system of Figure 6.1.

The Spectrum Analyzer

The spectrum analyzer should be a high-sensitivity, low-frequency (up to highest offset measured) analyzer capable of providing narrow resolution bandwidths. The HP 3585A Spectrum Analyzer is a good choice for automated spot measurements of SSB phase noise over a wide offset range (20 Hz to 40 MHz). The HP 3582A Spectrum Analyzer uses Fast Fourier Transform Techniques and is efficient for rapid measurements of close-in phase noise (0.02 Hz to 25.5 kHz). Both manual and automated measurements will be discussed in detail in this chapter.

Following are spectrum analyzer features of the HP 3582A and 3585A that are useful for phase noise measurements:

- programmability.
- rms-averaging mode for enhanced noise measurement repeatability.

driven by the 10 kHz beat note. Here, 40 dB is chosen for illustration. The actual amount of attenuation necessary will vary, depending on the sensitivity required of the measurement, the linear operating range of the mixer, the characteristics of the low noise amplifier, and the output level characteristics of the synthesizer under test.

Note that it makes no difference which source is connected to which mixer input as long as the proper levels are maintained. If the synthesizer under test has sufficient output to drive the LO port of the mixer, it is usually more convenient to connect the HP 8662A/8663A to the RF input, since 40 dB of attenuation can be added by simply decrementing the HP 8662A/8663A output level by 40 dB. If the HP 8662A/8663A must be used to provide the +10 dBm LO drive an external attenuator such as the Hewlett-Packard Model 355D may be used to provide the required attenuation for the test signal at the RF mixer port.

3. Set the HP 3582A Spectrum Analyzer for a 0 to 25 kHz span, 10 dB/division, flat top passband, averaging off. Enable the marker and set it on the 10 kHz beat note. Set a reference at this carrier level by pressing



Enter the relative mode by pressing



To obtain readings in dBc/Hz, enable the automatic bandwidth normalization by pressing



Calibration is complete.

Setting Quadrature

Quadrature setting consists of offsetting the HP 8662A/8663A frequency by 0.1 Hz until the two sources are in quadrature, then resetting the HP 8662A/8663A frequency to exactly F_c .

4. On the HP 8662A/8663A, press



5. Set an HP 8662A/8663A frequency increment of 0.1 Hz (0.2 Hz above 640 MHz). Press



With the HP 1745A Oscilloscope set at 0.1 volts/div and dc coupled, monitor the 0.1 Hz beat note on the oscilloscope. As the trace passes through 0 volts dc press



to hold the mixer inputs in quadrature. Note: due to the need for phase-continuous HP 8662A/8663A frequency switching in performing this step, the



frequency offset sequence, or the reverse, depends on the carrier frequency. If the level on the oscilloscope jumps abruptly to a new offset when the second INCREMENT button is pressed use the reverse sequence.



Measurement

6. Set the HP 3582A Spectrum Analyzer to span the desired offset frequency and increase the input sensitivity in 10 dB steps until the "overload" indicator just remains unlit, then back off one step.

7. Place the HP 3582A in the RMS average mode, select the desired number of averages and press



As the HP 3582A takes readings, monitor the HP 1745A to ensure that the inputs to the mixer remain within the desired limits about quadrature.

8. When the HP 3582A is finished averaging, move the marker to the desired offset frequency and note the reading on the screen.

9. Correct the reading taken above by the following corrections factors: minus 40 dB for the attenuation added during calibration minus 6 dB to convert measured reading to $\mathcal{L}(f)$.

The resulting number is equal to the SSB phase noise level in dBc/Hz provided the phase noise level of the reference is at least 10 dB below that of the source under test. If not, the SSB phase noise level is the upper limit of either source. Notice that the HP 3582A does not require any of the spectrum analyzer correction factors discussed previously. This is due to its automatic bandwidth normalization feature and digital Fast Fourier Transform operation.

10. If the phase noise at other offsets not currently displayed on the HP 3582A is required, repeat steps 6 through 9. Generally, recalibration is not necessary if power levels are unchanged, but quadrature may have to be reset from time to time, depending upon the stability of the synthesizer under test.

PRECAUTIONS

The following potential problems should be considered when making the above measurements.

- Non-linear operation of the mixer, due to over-driving, can result in calibration error.
- RF signal harmonics can cause K_{ϕ} to deviate from V_{bpeak} , causing calibration error.
- The amplifier or spectrum analyzer input can be saturated during calibration or by high spurious signals such as line frequency multiples.
- Closely-spaced spurious may give the appearance of continuous phase noise when spectrum analyzer resolution is insufficient.
- Interface impedances should remain unchanged between calibration and measurement.
- In residual measurement systems, phase noise of the common reference oscillator may be insufficiently cancelled due to delay-time differences between the two branches.
- Noise from power supplies can be a dominant contributor to measured phase noise.
- Peripheral instrumentation such as oscilloscopes, analyzers, counters, and DVMs can inject noise.
- Microphonic noise might excite significant phase noise in devices.

This list of potential problems points out that much care must be exercised when very low SSB phase-noise measurements are made. However, if these points are considered carefully, the system of Figure 6.1 will measure SSB phase noise as low as the phase noise level of the HP 8662A/8663A itself (Figure 4.1). Figure 6.4 shows the SSB phase noise of the HP 8660C Synthesized Signal Generator (top) and the HP 8662A/8663A (bottom) as seen on the HP 3582A Spectrum Analyzer display. Note the flattening effect of displaying phase noise on a linear frequency scale.

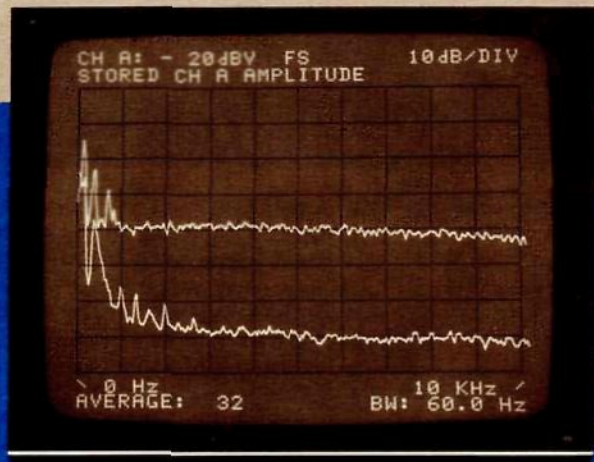

Figure 6.4.
Phase-locked two-source phase noise measurement.

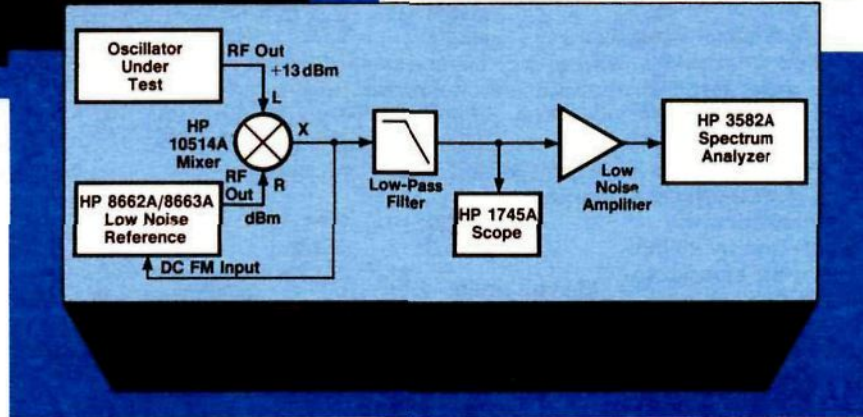

Figure 6.3.
Phase-locked two-source phase noise measurement.

Phase-Locked Measurements Using the HP 8662A/8663A DC FM Mode

One of the most common phase noise measurements involves measuring the SSB phase noise of a free-running oscillator using the two-source technique. Since such an oscillator does not operate from a reference oscillator, phase quadrature must be maintained by phase-locking one of the two sources to the other. To avoid phase-noise cancellation by loop tracking, the bandwidth of the phase-locked loop must be much less than the lowest offset frequency of interest. Although it makes no difference which source is phase-locked to which, it is generally most convenient to phase-lock the HP 8662A/8663A used as the low-noise reference to the source under test. A system for making phase-locked phase noise measurements using the DC FM capability of the HP 8662A/8663A is shown in Figure 6.3.

The output of the mixer is connected to the dc-coupled FM input of the HP 8662A/8663A. Because the resulting phase-locked loop is essentially first order, the loop bandwidth can be calculated and is given by the formula

$$BW_{f(3\text{ dB})} = K_0 K_\phi$$

where K_0 = the HP 8662A/8663A "VCO gain constant", in Hz/volt and is just equal to the HP 8662A/8663A front panel FM deviation setting, and K_ϕ = phase detector constant, in volts/radian (V_{bpeak}) as given in Chapter 5.

When the HP Model 10514A Double-Balanced Mixer is used with input levels of 0 dBm at the RF port and +10 dBm at the LO port, the following rule of thumb applies: phase noise measurements made at carrier offsets greater than or equal to the HP 8662A/8663A front panel FM peak deviation setting will result in a loop attenuation error of <0.5 dB.

PHASE-LOCKED MEASUREMENT PROCEDURE

The procedure for manual phase-locked measurements of absolute phase noise using the system shown in Figure 6.3 is as follows:

Calibration

The calibration procedure involves measuring the level of the carrier so that the spectrum analyzer can make measurements of phase noise levels relative to that carrier.

1. Set the HP 8662A/8663A frequency to the approximate frequency of the oscillator under test. Press



Set the HP 8662A/8663A amplitude to 0 dBm and set an amplitude increment of 40 dB. Press



Set a frequency increment of 10 kHz. Press



2. Adjust the HP 8662A/8663A frequency to obtain a beat frequency at the mixer output of approximately 10 kHz.

3. Set the HP 3582A Spectrum Analyzer for a 0 to 25 kHz span, 10 dB/division, flat top passband shape, averaging off. Enable the marker and set it on the 10 kHz beat note from the mixer. Set a reference at this carrier level by pressing



Enter the relative mode by pressing



To obtain readings in dBc/Hz, enable the automatic bandwidth normalization by pressing $\div \sqrt{BW}$. Calibration is complete.



Setting Quadrature

The following procedure phase-locks the HP 8662A/8663A to the source under test and adjusts the phase relationship to phase quadrature.

4. On the HP 8662A/8663A press



5. Set the HP 8662A/8663A FM deviation to 1 kHz. Press



Adjust the HP 8662A/8663A frequency slowly until phase locking is observed on the HP 1745A. This is indicated by a constant level on the scope. Adjust the HP 8662A/8663A frequency until that dc level is equal to 0 volts.

Measurement

6. Set the HP 3582A Spectrum Analyzer to span the desired offset frequency and increase the input sensitivity in 10 dB steps until the "overload" indicator just remains unlit, then back off one step.

7. Place the HP 3582A in the RMS average mode, select the desired number of averages, and press



As the HP 3582A takes readings, monitor the HP 1745A to ensure that the inputs to the mixer remain within the desired limits about quadrature.

8. When the HP 3582A is finished averaging, move the marker to the desired offset frequency and note the reading on the screen.

9. Correct the reading taken above by applying the following correction factors:

minus 40 dB for the attenuation during calibration.

minus 6 dB to convert measured reading to $\mathcal{L}(f)$.

As in the previous procedure, the resulting number is equal to the maximum SSB phase noise level in dBc/Hz of either source. Notice that the HP 3582A does not require any of the spectrum analyzer correction factors discussed in Chapter 5. This is due to its automatic bandwidth normalization feature and digital Fast Fourier Transform operation.

10. If the phase noise at other offsets not currently displayed on the HP 3582A is required, repeat steps 6 through 9. Generally, recalibration is not necessary, but quadrature may have to be reset

from time to time, depending upon the stability of the source under test.

Comments

With very stable sources under test, HP 8662A/8663A FM deviations as small as 0.1 kHz may be used, enabling phase noise measurements to be made as close to the carrier as 100 Hz. In this case, the HP 3582A Spectrum Analyzer can be placed in the single sweep mode and the trigger can be manually "armed" by the operator as the HP 8662A/8663A frequency is adjusted to maintain quadrature. The averaging feature can still be used, except that the averages must be taken manually.

This system can measure absolute SSB phase noise as low as that of the HP 8662A/8663A in the DC-FM mode (Figure 6.5).

as phase noise measurements, the most obvious being speed. A second advantage lies in the inherent repeatability of automated measurements that results from the elimination of operator error and inconsistency. Still another advantage is apparent in the tremendous data gathering and documentation ability of a desktop computer used in conjunction with a printer, plotter, or CRT display.

An example of an automated system for residual phase noise measurements is shown in Figure 6.6. This system is based on the Hewlett-Packard Model 9836 Computer and uses the HP 3585A Spectrum Analyzer. Typical system software written for the HP 9836 is presented in Figure 6.7. The software flow-chart in Figure 6.8 shows that the software structure corresponds to the manual measurement procedure described in the preceding section.

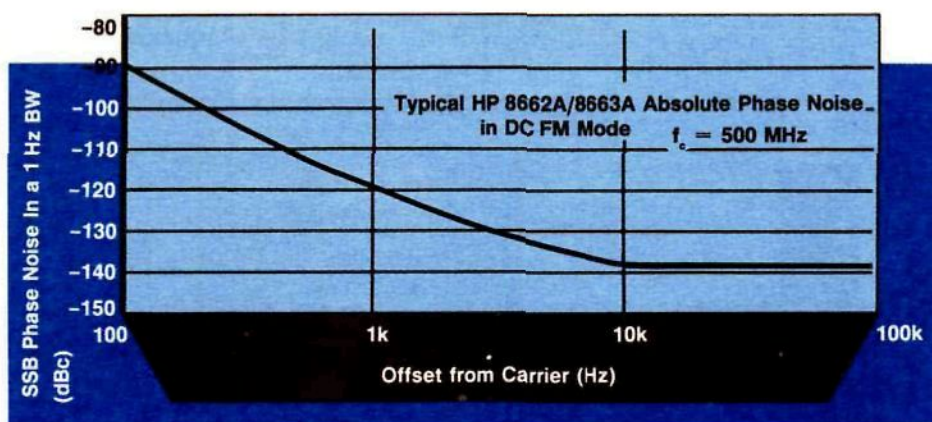

Figure 6.5. Typical HP 8662A/8663A absolute phase noise in DC-FM mode.

Automated SSB Phase Noise Measurements Using the HP-IB

The phase noise measurement systems shown in Figures 6.1 and 6.3 can be automated. In the example program, the HP 3585A Spectrum Analyzer is substituted for the HP 3582A Spectrum Analyzer used in the manual measurement system. The HP 3585A is well suited to automated measurements since it can be programmed to make measurements at specific offsets, rather than over a band of frequencies. The addition of an HP 9836 computer to control the spectrum analyzer and collect and display data via the Hewlett-Packard Interface Bus (HP-IB) make the system fully automated. There are many advantages to automating complex measurements such

The routine is automated, except for calibrating the beat note and setting quadrature. To calibrate the beat note, set up a beat note on the spectrum analyzer or the oscilloscope and measure its level, as described in the Measurement Procedure Calibration section. The calibration factor as measured on the spectrum analyzer is the rms value and is 3 dB less than peak. Measured on the oscilloscope it is read directly in peak volts. This calibration factor, in peak volts, is the slope at the zero crossing in volts/radian.

To set quadrature, follow steps 4 and 5 of the measurement procedure section.

Once quadrature is set, the program asks for the gain of the amplifier, if applicable, and then instructs the user to connect the amplifier output to the input of the analyzer. The analyzer settings

and resolution bandwidth are automatically selected. $\mathcal{L}(f)$ is computed from the level in dBv, as read from the spectrum analyzer, minus the gain of the amplifier, minus the calibration factor.

The phase-noise curve in dBc/Hz versus log frequency is plotted on an HP 2671G Printer. The printing and plotting subroutines may be changed to meet individual documentation requirements. The number of offsets at which phase noise is measured is determined by the number of steps chosen in the beginning of the program. The measurement range, 20 Hz to 10 kHz, is scaled in logarithmic steps accordingly.

As an example of the power of HP-IB automation, refer to the phase noise graph in Figure 6.9. This graph was obtained from a system similar to that shown in Figure 6.6 using 100 offset points.

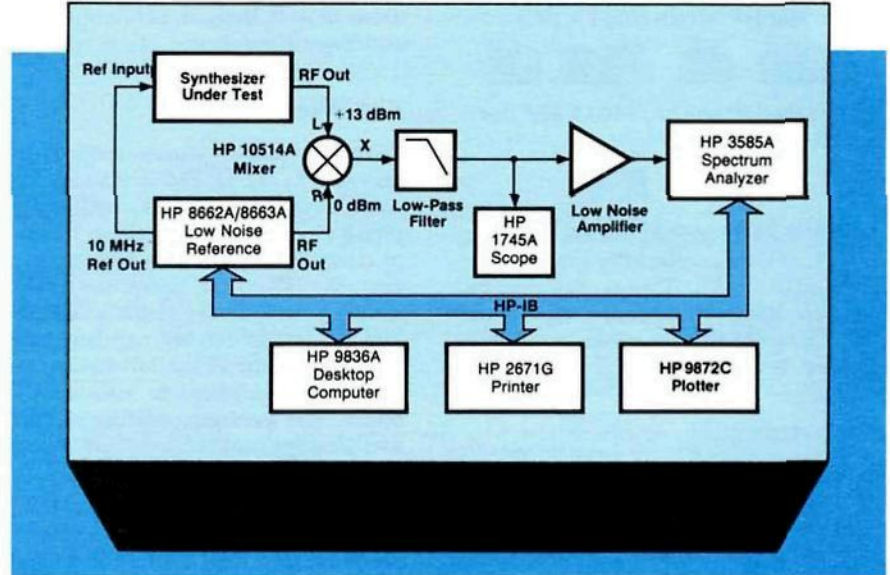

Figure 6.6. Automated system for phase noise measurement.

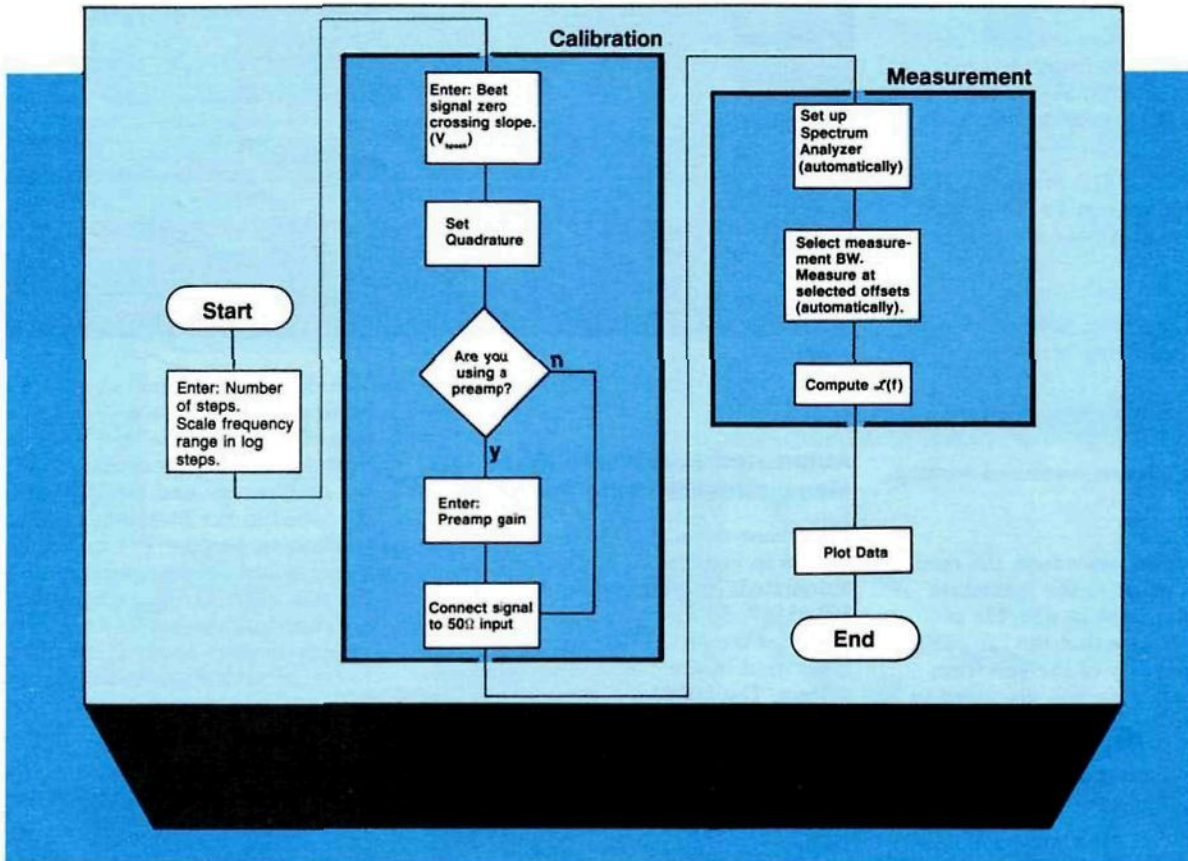

Figure 6.8. Phase noise measurement software flowchart.

```

10 GRAPHICS OFF
20 PRINT "3585/9836 PHASE NOISE MEASUREMENT ROUTINE 20 Hz TO 10 kHz"
21 DISP "PRESS CONTINUE TO BEGIN."
30 PAUSE
40 COM /Phase/ R(1001),R#(11),F1,F2,S,R,B#(11),G,B,F(1001)
50 REMOTE 713
60 OUTPUT 713;"PP"
70 F1=20
80 F2=10000
100 INPUT "How many steps (1000 max)?" ;S
110 Img: IMAGE "RB",4D,"HZ FR",8D,"HZ CA",52" ;Turns input autoranging
120 ;off, sets single sweep.
130 ;loads stop & start freq.
140 ;clears trace & starts
150 OUTPUT 713 USING Img;F2,F1 ;single sweep.
160 CALL Quadrature
170 CALL Measure
180 CALL Plot
190 BEEP
200 END
210 ;
220 ;
230 SUB Quadrature
240 COM /Phase/ R(1001),R#(11),F1,F2,S,R,B#(11),G,B,F(1001)
250 INPUT "What is the beat signal zero crossing slope [VOLTS/RAD]?" ;V
260 P=20*LGTV-3 ;Converts entry to log.
270 DISP "Set the sources to quadrature, then press CONTINUE."
280 PAUSE
290 INPUT "Are you using a preamp (YES or NO)?" ;B#
300 IF B#(1)="" THEN Ipt
310 INPUT "What is the gain of the preamp [dB]?" ;G
320 Ipt: DISP "Connect the signal to the 50 ohm input, press CONTINUE."
330 OUTPUT 713;"I2 RL DV" ;Selects 50 ohm input.
340 ;and dBu reference level.
350 PAUSE
360 SUBEND
370 ;
380 ;
390 SUB Measure
400 COM /Phase/ R(1001),R#(11),F1,F2,S,R,B#(11),G,B,F(1001)
410 DISP "MEASUREMENT IN PROGRESS."
420 OUTPUT 713;"S3 HL1"
430 ;Sets manual frequency
440 ;& noise level modes.
450 ;Res bandwidth variable.
460 FOR I=1 TO S
470 P=F1*10**(LGTF2-LGTF1)**I ;Calculates log frequency.
480 Bdu: B=3 ;Selects 3, 30, or 1000
490 IF P<1000 THEN B=30 ;Hertz res bandwidth depending
500 ;on frequency
510 IF P<1.E+4 THEN B=300
520 IF P<1.E+4 THEN B=1000
530 B=1000
540 B#B: IF B#1 THEN Frq ;Skips res bw output if
550 ;no change.
560 B1=B
570 Img2: IMAGE "RB",4D,"HZ"
580 OUTPUT 713 USING Img2;B
590 Frq: IMAGE "S3",8D,"HZ FR D1 T5"
600 OUTPUT 713 USING Frq;P
610 ;Outputs frequency
620 ;& triggers measurement.
630 ENTER 713;X
640 R(I)=X-G-R
650 F(I)=P ;Computes L(f) for quad
660 ;det & stores in array.
660 PRINT F(I),R(I)
670 NEXT I
680 SUBEND
690 Plot: SUB Plot ;Plot on CRT
700 COM /Phase/ R(1001),R#(11),F1,F2,S,R,B#(11),G,B,F(1001)
701 DIM Offset_data(29)
710 INPUT "What is top of vertical scale - YMAX [dB]?",Y2
721 Y1=Y2-100
740 OUTPUT 1 USING "#,@" ;Clears CRT
750 GINIT ;Clears CRT
760 PLOTTER IS 1,"INTERNAL"
770 GRAPHICS ON
780 MOVE 12,95 ;Begin label routine.
790 LABEL "SINGLE SIDEBAND PHASE NOISE DBC/HZ"
800 LDIR P1/2
810 MOVE 3,40
820 CSIZE 3
830 LABEL "SSB Phase Noise (dBc/Hz)"
840 LDIR 0
850 MOVE 50,2
860 LABEL "Frequency (Hz)"
871 Y=INT((Y2-Y1)/10) ;Draw X and Y axes
873 CLIP 20,120,15,90
874 Number=90
880 FRAME
881 CLIP OFF
883 FOR I=1 TO Y
884 MOVE 20,Number
885 DRAW 120,Number
886 Number=Number-(75/Y)
887 NEXT I
888 Number=90
889 X=Y2
891 FOR I=1 TO Y+1
892 MOVE 13,Number
893 LABEL USING "#,K";IX
894 Number=Number-(75/Y)
895 X=X-Y
897 NEXT I
899 Draw: DATA 1,2,3,4,5,6,7,8,9,10,20,30,40,50,60,70,80,90,100,200
899 RESTORE Draw
900 FOR I=1 TO 29
901 READ Offset_data(I)
902 NEXT I
903 FOR I=1 TO 29
904 Logline=(20+30*(LGTOffset_data(I)))
905 MOVE Logline,90
906 DRAW Logline,15
907 NEXT I
908 Label: DATA 100,1000,10000
909 RESTORE Label
910 FOR I=1 TO 3
911 READ Label_data(I)
912 NEXT I
913 FOR I=1 TO 3
914 Logline=(20+30*(LGTOffset_data(I)/10))
915 MOVE Logline,10
916 LABEL USING "#,K";Label_data(I)
917 NEXT I
1140 Plt: ;Plot data routine.
1150 Rmp=(90+75*((R(I)-Y2)/ABS(Y2-Y1)))
1160 Logfreq=(20+30*(LGTF(I)/10))
1170 MOVE Logfreq,Rmp
1180 FOR I=2 TO S
1190 Rmp=(90+75*((R(I)-Y2)/ABS(Y2-Y1)))
1200 Logfreq=(20+30*(LGTF(I)/10))
1204 DRAW Logfreq,Rmp
1240 NEXT I
1242 PRINTER IS 1
1243 DUMP GRAPHICS #701
1250 LOCAL 713 ;Sets analyzer to local.
1260 SUBEND

```

Figure 6.7.
HP 9836 Software for Automatic Phase Noise Measurements.

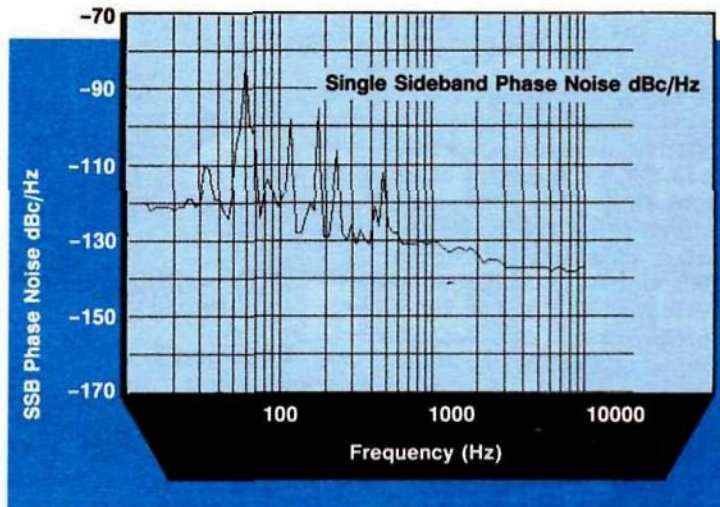

Figure 6.9
HP 8662A/8663A Residual SSB Phase Noise at $F_c = 420$ MHz

Chapter 7

Using the HP 8662A/8663A at Microwave Frequencies with the HP 3048A Phase Noise Measurement System

Why Use the HP 8662A/8663A at Microwave Frequencies?

As discussed in Chapter 2, in recent years the importance of phase noise in radar and communications systems has grown significantly. Modern systems such as two-way voice-grade radio, digital communications, and doppler radar have become increasingly dependent on low phase-noise signals, both for signal simulation and system testing.

Two-way radios usually operate over frequencies within the range of the HP 8662A, up to 1280 MHz (see Chapter 8), and the HP 8663A which operates up to 2560 MHz satisfies most LO requirements (see Chapter 9). However, many other phase-noise-dependent systems operate at frequencies well above the HP 8663A frequency range. For example, airborne doppler radar operates at a frequency around 10 GHz. Low-phase-noise signals are absolutely critical for these systems, both close to the carrier (representing slow-moving objects), and far away from the carrier (echoes from objects moving at higher velocities). These low-phase-noise microwave signals can be realized by frequency multiplying the output of the HP 8662A/8663A.

In addition to signal simulation, the multiplied low-phase-noise output from the HP 8662A/8663A can be used for phase-noise measurements on microwave sources and systems. This chapter discusses multiplying the HP 8662A/8663A to microwave frequencies and using it as the low noise reference in a microwave phase-noise measurement system, the HP 3048A option 100/200 and option 300.

The HP 3048A with options 100/200 and 300 is a complete, automated system for phase-noise measurements from 5 MHz to 18 GHz. It consists of an HP 3048A Phase Noise Measurement System with an HP 8662A/8663A synthesized signal generator (option 100/200), an HP 11729C Carrier Noise Test Set (option 300), and an HP Series 200 or 300 Desktop Computer to control the system.

Effect of Multiplication on Signal Noise

Basic modulation theory and spectral-density relationships can be used to derive the effect of multiplication on

signal noise. In Chapter 2, $\mathcal{L}(f)$ was defined as the ratio of the single-sideband phase noise power in a 1 Hz bandwidth, f_m hertz away from the carrier frequency, to the total signal power. This definition of $\mathcal{L}(f)$ is primarily applied to random noise. To determine the effect of multiplication, a signal with sinusoidal frequency modulation is considered first.

$$f(t) = f_0 + \Delta f_{\text{peak}} \cos 2\pi f_m t$$

$$\phi(t) = \int 2\pi f(t) dt$$

$$V(t) = V_s \cos [2\pi f_0 t + \phi(t)]$$

$$V(t) = V_s \cos (2\pi f_0 t + \frac{\Delta f_{\text{peak}}}{f_m} \sin 2\pi f_m t)$$

For the first order sideband the single-sideband-to-total-carrier-power ratio is given by:

$$\frac{V_{\text{ssb}}}{V_s} = J_1 \left(\frac{\Delta f_{\text{peak}}}{f_m} \right)$$

For small modulation index,

$$\frac{\Delta f_{\text{peak}}}{f_m} \ll 1$$

The single-sideband-to-carrier ratio is approximated by:

$$J_1 \left(\frac{\Delta f_{\text{peak}}}{f_m} \right) \approx \frac{1}{2} \frac{\Delta f_{\text{peak}}}{f_m} \approx \frac{1}{2} \Delta \phi_{\text{peak}}$$

and all other sidebands are negligible.

$$\mathcal{L}(f) \equiv \left| \frac{V_{\text{ssb}}^2}{V_s^2} \right|$$

or in logarithmic form

$$\mathcal{L}(f) = 20 \log \frac{\Delta f_{\text{peak}}}{f_m} - 6 \text{ dB}$$

Equation 7.1

For a more complete derivation of $\mathcal{L}(f)$, see "Today's Lesson—Learn about Low-Noise Design", Part I and Part II, Microwaves, April and May 1979.

Equation 7.1 is in a convenient form for calculating the increase in phase noise

when a signal is frequency multiplied. Modulation theory says that when a signal $f \pm \Delta f$ is doubled, the frequency deviation is doubled, but the rate of modulation remains the same. Considering phase noise as angular modulation on a carrier, doubling the carrier frequency will yield twice the frequency deviation at the same rate. Substituting for $\mathcal{L}(f)$ in equation 7.1 yields

$$\mathcal{L}(2f) = 20 \log \frac{2\Delta f_{\text{peak}}}{f_m} - 6 \text{ dB}$$

$$\text{and } \frac{\mathcal{L}(2f)}{\mathcal{L}(f)} = 6 \text{ dB}$$

Therefore, each doubling of the carrier frequency results in 6 dB higher phase noise.

HP 8662A/8663A Phase Noise Performance at Microwave Frequencies

The above relationship shows that multiplying a 1000 MHz signal directly from the HP 8662A/8663A front-panel output 10 times to a frequency of 10 GHz increases the phase noise 20 log 10 or 20 dB. Figure 7.1 is a plot of the resultant phase noise of the multiplied signals versus the phase noise of the Hewlett-Packard Model 8672A Microwave Synthesized Signal Generator at the same frequency.

The graph shows that the signal from the HP 8662A/8663A multiplied up to 10 GHz has noise 20 dB lower at offsets from 100 Hz to 10 kHz than that noise provided by a typical microwave generator. However, generating a low noise signal by simply multiplying the front-panel output has trade-offs. First, the broadband noise of a multiplied front panel HP 8662A/8663A signal is somewhat higher than that of typical microwave synthesizers. Second, whenever a signal is externally multiplied, unwanted spurious responses are also created, and the output level calibration is lost. AM modulation performance is severely limited, and the maximum available output power is significantly reduced. The following section will discuss an alternate multiplication scheme, employed in the HP 3048A option 300 Phase Noise Measurement System, which minimizes these disadvantages.

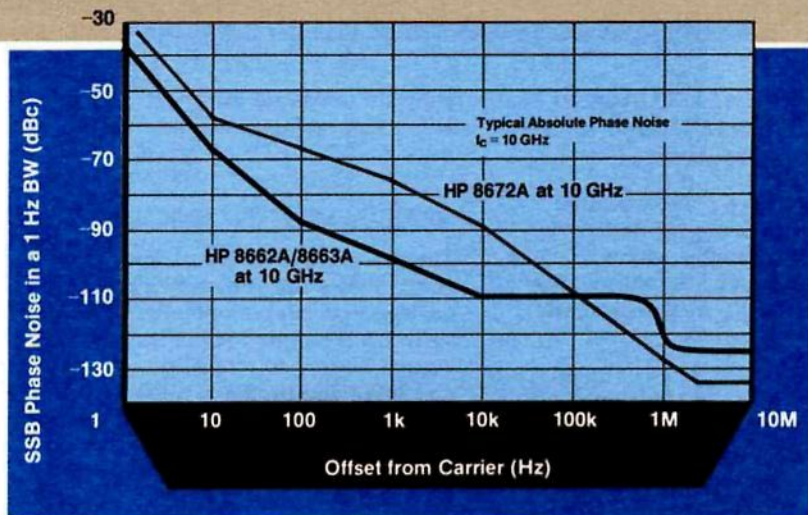

Figure 7.1.
Phase noise comparison of HP 8662A/8663A and HP 8672A at 10 GHz.

Note: If signal generator characteristics are needed at microwave frequencies, but the phase noise of the HP 8672A is not adequate for the application, there is a simple technique which uses the HP 8662A/8663A as an LO substitute for the VCO in one of the HP 8672A's phase lock loops. This method results in improved phase noise performance over the standard HP 8672A, while maintaining the maximum output level, output level calibration, amplitude modulation, and spurious performance of the HP 8672A. At the same time, increased frequency resolution and frequency-modulation capability are provided. See Chapter 11 for the block diagram and system performance.

Using the HP 8662A/8663A and the HP 11740A for Low-Noise Microwave Signal Generation

Figure 7.1 shows the level of phase-noise performance that can be achieved by multiplying a signal from the front panel of the HP 8662A/8663A. Though useful for many applications, this does not represent the maximum performance level which can be obtained. Chapter 3 discussed the design of the HP 8662A/8663A reference section, a critical subblock where low noise design was emphasized. This carefully designed low noise HP 8662A/8663A reference section can be utilized in a low-phase-noise multiplication scheme for microwave signal generation.

In the reference section of the HP 8662A/8663A, the 10 MHz reference signal is directly multiplied up to a frequency of 640 MHz through the use

of six frequency doublers (Figure 7.2). Theoretically this frequency multiplication would increase the phase noise of the internal reference by $20 \log(640/10)$ or 36 dB, resulting in a noise characteristic as shown in Figure 7.3. However, to reduce sideband noise, monolithic crystal filters were added in the reference multiplier chain at 40 and 160 MHz. These filter the noise sidebands at offsets greater than about 4 kHz (6 kHz bandwidth at 40 MHz) and 10 kHz (18 kHz BW at 160 MHz), to yield a 640 MHz signal with phase noise typically -95 dBc at 10 Hz offset from the carrier, decreasing to a noise floor of greater than -160 dBc at offsets greater than 20 kHz.

This directly synthesized, low-phase-noise 640 MHz signal is available from the rear panel of all HP 8662As and 8663As. The HP 8662A/8663A option 003 provides specified absolute phase

noise for this 640 MHz signal, as shown in Table 7.1. The signal is tapped off the 640 MHz signal from the reference section, before it is input to any of the phase locked loops. Since the additive noise of the output phase locked loops is not present, it has significantly lower phase noise than the signals available at the front panel of the instrument.

The low-noise rear-panel 640 MHz output from the HP 8662A/8663A is utilized by the HP 3048A option 003 to provide a low noise microwave reference signal. This critical multiplication is performed by the HP 11729C Carrier Noise Test Set, shown in Figure 7.4, which is option 003 of the HP 3048A System (Figure 7.5 shows how the HP 11729C interfaces with the HP 3048A).

The 640 MHz reference input to the HP 11729C multiplier chain first passes through a 640 MHz SAW bandpass filter, to reject 10 MHz and 20 MHz reference harmonic spurious sidebands which are caused by the synthesis process in the HP 8662A/8663A, and to reduce noise 1 MHz away from the carrier and beyond. A power amplifier then provides sufficient drive level to a step-recovery-diode multiplier* which generates a comb of frequencies spaced 640 MHz apart extending up to 18 GHz. A circulator isolates the diode multiplier from bandpass filter reflections, and the microwave bandpass filter selects the comb line close to the frequency of the device under test. The result is a clean multiple of the 640 MHz signal, within 1280 MHz of the signal to be tested. This low-noise reference signal downconverts the signal under test to an

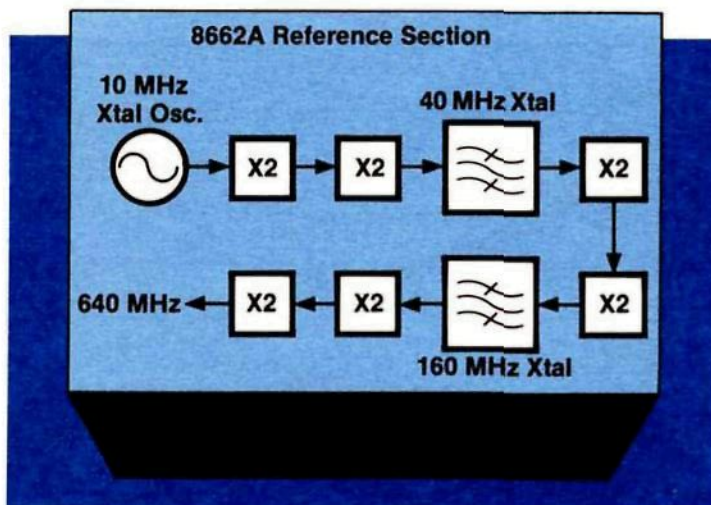

Figure 7.2.
Direct synthesized 640 MHz signal.

IF that is less than 1280 MHz. (The basic measurement technique is the phase detector method. Refer to HP Product Note 11729B-1 for a more detailed discussion of the phase detector method for measuring phase noise.) The phase-noise spectral density of this low-frequency signal is detected and analyzed by the HP 3048A. The detec-

Using the HP 3047A/11740A to Make Phase-Noise Measurements on Microwave Sources

Chapter 6 describes a measurement system which uses the HP 8662A/8663A as a low noise reference source to make manual or automatic SSB phase-noise measurements at RF frequencies. The

software to control the system. Basic HP 3048A performance specifications are listed in Table 7.2.

MEASUREMENT TECHNIQUE

The extensive software package that accompanies the system has been designed for simple operation. The software is simply loaded into the system and by selecting from menus and following prompts, measurements are automatically executed and the results plotted. The HP 3048A provides three measurement techniques: phase-detector with voltage control, phase-detector without voltage control, and frequency-discriminator. The data can be displayed in any of five formats: $\mathcal{L}(f)$, $S_p(f)$, $S_v(f)$, $S_y(f)$ and $\sigma(\tau)$. $\mathcal{L}(f)$, $S_p(f)$ and $\sigma(\tau)$ were discussed in Chapter 2. $S_v(f)$ and $S_y(f)$, the mean square frequency fluctuations and the mean square fractional frequency fluctuations, respectively, are discussed in the HP 3048A Phase Noise Measurement System Operating Manual.

Offset from carrier	Absolute Phase Noise (dBc) Option 003
10 Hz	-84
100 Hz	-104
1 kHz	-121
10 kHz	-145
100 kHz	-157
1 MHz	-157

Table 7.1. HP 8662A/8663A Opt. 003 specified absolute phase noise at 640 MHz.

tion and analysis portion is the HP 3048A Phase Noise Measurement System which is shown in Figure 7.5.

*For more information on methods of frequency multiplication, see "Generation of Low Phase Noise Microwave Signals", HP RF and Microwave Symposium Paper, Dieter Scherer, and Hewlett-Packard Application Note 983, Comb Generator Simplifies Multiplier Design.

components discussed in Chapter 6 for phase detector measurements can be lumped into three categories: the reference section, the phase-detector/quadrature circuitry, and the baseband-analysis section. The components of the HP 3048A Microwave System fill these categories: the HP 8662A/8663A and the HP 11729C provide the low noise reference, the quadrature and phase-detector circuitry and baseband analysis is provided by the HP 3048A Interface box. The HP 3048A comes complete with

DATA INTERPRETATION

The HP 3048A is a powerful system that measures and displays phase-noise data. The system will monitor quadrature and alert the user to out-of-lock conditions during a measurement.

The HP3048A also identifies spurs. Spurs are caused by both mechanical and electrical phenomena. Figure 7.6 is a typical HP 3048A phase noise graph of the HP 8662A/8663A. The spurs appearing in the graph are most likely line-related spurs and microphonic spurs.

Markers are available to pinpoint the exact frequency and amplitude of a particular spur, and slope lines indicate the relative amplitude change of noise versus offset frequency.

HP 3048A SYSTEM PERFORMANCE

Figure 7.6 shows specified system noise floor and spurious. Table 7.2 lists abbreviated specifications for the HP 3048A. In addition to excellent spectral purity, the HP 3048A is accurate within 2 dB for offsets of 0.01 Hz to 100 kHz. By optioning other spectrum analyzers the HP 3048A will measure out to 1 MHz with ± 2 dB accuracy and out to 40 MHz with ± 4 dB accuracy.

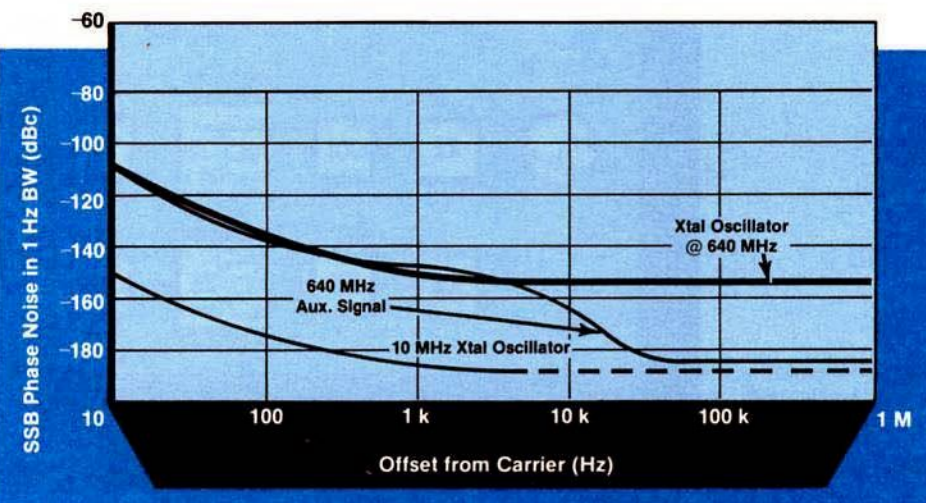

Figure 7.3. Phase noise of 640 MHz reference signal.

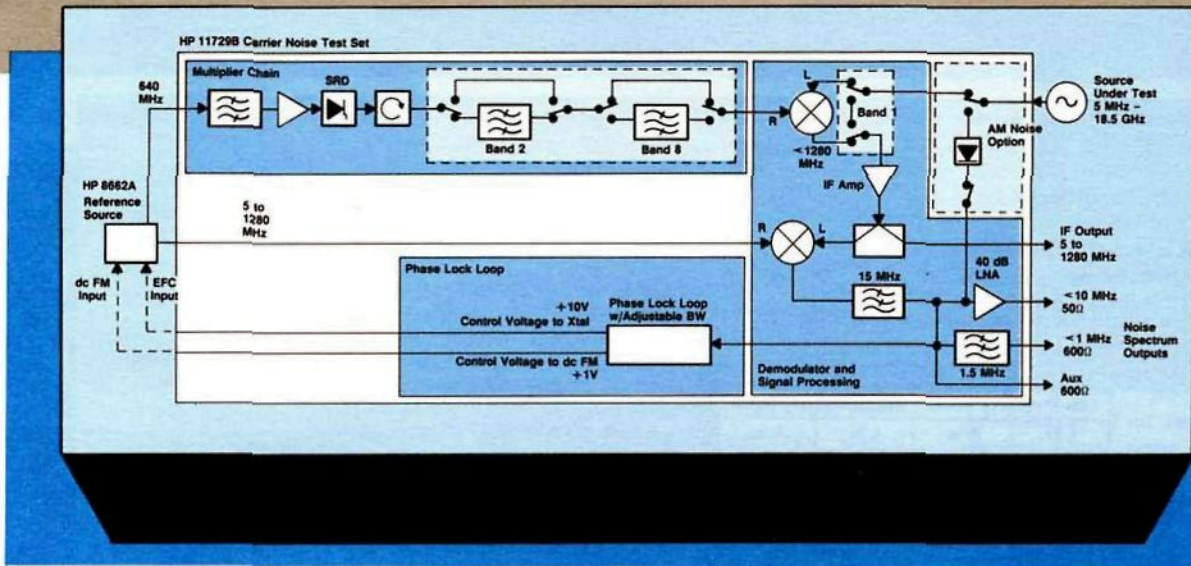

Figure 7.4.
HP 11729C block diagram.

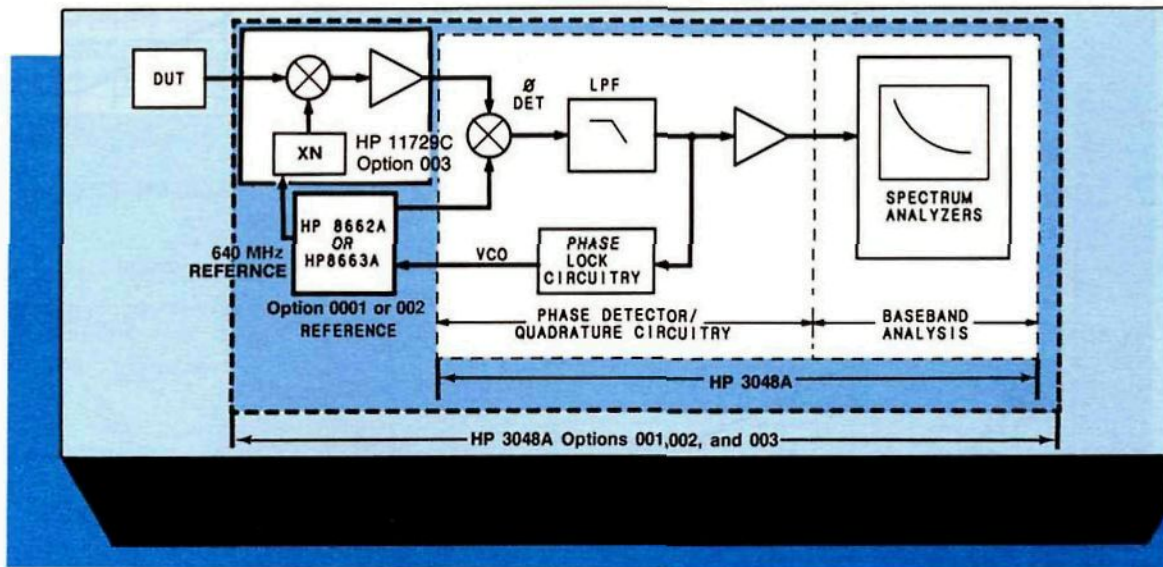

Figure 7.5.
HP 3048A Opt. 003 system block diagram.

The HP 3048A also has internal sources to provide complete system calibration.

MEASUREMENTS ON PULSED SOURCES

The HP 3048A system is also capable of making measurements on pulsed sources. These measurements create their own set of limitations, mainly due to duty cycle. Since the reference is on all the time, but the DUT pulsed, the phase detector sensitivity decreases as a function of duty cycle. As duty cycles become very low the noise of the measurement system predominates.

In order to make pulsed measurements with the HP 3048A system, an external phase detector may be necessary at the HP 11729C IF output port. The L port

drive is provided by the front panel of the HP 8662A/8663A. After the phase detector, a low pass filter removes the sum mixing products and the PRF lines. The resulting signal is applied to the HP 3048A Signal Input port. This configuration provides measurements on pulsed sources with duty cycles down to approximately 20%.

SUMMARY

The HP 8662A/8663A's low phase noise properties can be used to provide state-of-the-art phase noise performance at microwave frequencies. The standard HP 8662A/8663A front panel signal can be multiplied up to microwave, offering close-in phase noise improvements of tens of dB's over other available microwave sources. Alternatively, to produce lower noise performance at microwave

frequencies, a very-low-noise HP 8662A/8663A reference signal can be used in a low noise multiplication scheme for microwave signal generation. This technique can be used to produce signals with absolute noise -71 dBc at a 10 Hz offset, with a noise floor greater than -135 dBc for a carrier frequency of 10 GHz . The same low-noise reference signal can also be used as the basis for an automated microwave phase noise measurement system such as the HP 3048A Phase Noise Measurement System.

Specifications describe the instruments' warranted performance. Supplemental characteristics are intended to provide information useful in applying the instrument by giving typical, but not warranted performance parameters. These are denoted as "typical," "nominal," or "approximate."

PHASE DETECTOR PORTS

Frequency

Range: 5 MHz to 1.6 GHz (low-frequency inputs)
Additional Range with Option 201: 1.2 to 18 GHz (high-frequency inputs) (The frequency range can be extended with a customer-supplied phase detector or frequency discriminator.)

Amplitude

	Low-Frequency Inputs		High-Frequency Inputs	
	L in	R in	L in	R in
Maximum Signal (dBm)	+23	+23	+10	+10
Minimum Signal (dBm)	+15	-5	+7	+0

Offset Frequency Range

0.01 Hz to 40 MHz for carriers from 95 MHz to 18 GHz
 0.01 Hz to 2 MHz for carriers from 5 MHz to 95 MHz
 (Assumes addition of 40 MHz spectrum analyzer to the system, otherwise offset range limited to 100 kHz.)

Accuracy (measurement of all noise and spurious present at the two inputs to the phase detector and system contribution):

±2 dB for 0.01 Hz to 1 MHz offsets
 ±4 dB for 1 MHz to 40 MHz offsets

System Phase Noise and Spurious Responses

(Does not include phase noise and spurious signals from a reference source.)

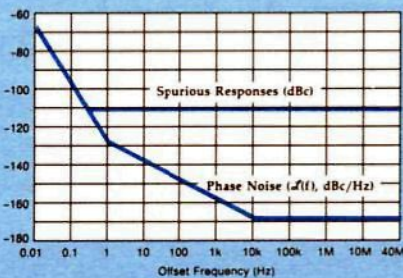

System Noise and Spurious Response Increase with Input Level Decrease

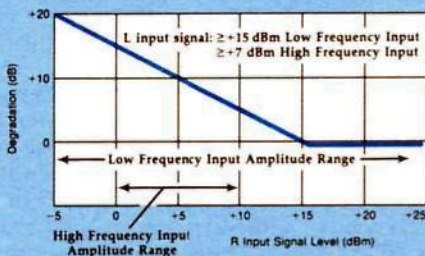

To determine system noise and spurious response levels, find the dB degradation at the signal input level from the lower graph and add to the curves of the upper graph. For example, if a +15 dBm signal is applied to the Low Frequency L Input and a +5 dBm signal to the R Input, the degradation is +10 dB. Therefore, the specified maximum spurious signal

level increases from -112 to -102 dBc at all offset frequencies and the system's maximum noise level at >10 kHz offset frequencies increases from -170 to -160 dBc/Hz.

NOISE INPUT PORT

(For use with external phase detector or frequency discriminator)

Frequency: 0.01 Hz to 40 MHz

Amplitude: 1 Volt peak maximum

Typical Input Impedance: 50Ω; return loss >9.5 dB (<2:1 SWR)

Accuracy: External phase detector or frequency discriminator measurements calibrated with ±1 dB accurate signals.

±2 dB for 0.01 Hz to 1 MHz offsets

±4 dB for 1 MHz to 40 MHz offsets

System Noise and Spurious Responses

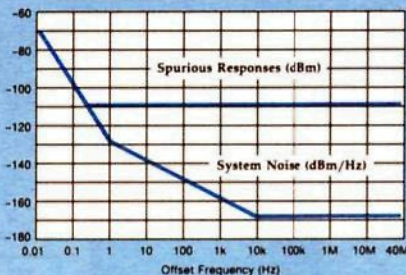

TUNING VOLTAGE OUTPUT

Voltage Range: ±10 volts

Current: ±20 mA maximum

Output Impedance: 50Ω nominal

SOURCE OUTPUT TYPICAL PERFORMANCE

10 MHz Source A

Amplitude: +15 dBm

Tuning: ±100 Hz

10 MHz Source B

Amplitude: +2 dBm

Tuning: ±1 kHz

350-500 MHz

Amplitude: +17 dBm

400 MHz

Amplitude: -5 dBm

Tuning: Fixed Frequency

Typical Noise and Spur Levels

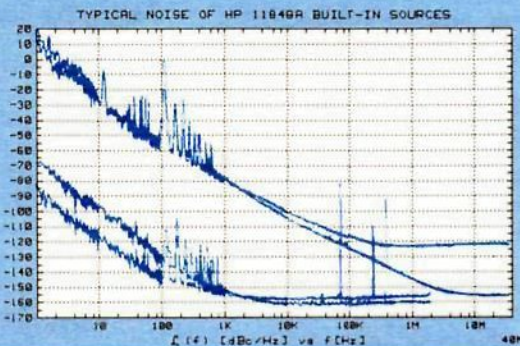

Table 7.2.
 HP 3048A phase noise measurement specifications.

The HP 3048A can be ordered with any of several optional signal generators as a reference source for phase noise measurements. The following specifications address system operation with these signal generators. The data that follows is in addition to that given previously under the heading of HP 3048A System Specifications. Refer to the data sheet for each signal generator for more complete information on each model.

OPTIONS 001 OR 002: ADDING THE HP 8662A OR 8663A SIGNAL GENERATOR

The following data applies only if either the HP 8662A Opt. 003 or 8663A Opt. 003 is used as the reference source to demodulate the test signal.

Frequency

Range: 100 kHz to 1280 MHz (to 2560 MHz with HP 8663A).¹

Resolution: 0.1 Hz, 0.2 Hz: 640 to 1280 MHz, 0.4 Hz above 1280 MHz.

Accuracy and Stability (internal 10 MHz quartz oscillator):

Aging rate $< 5 \times 10^{-10}$ /day after 10-day warm-up (typically 24 hrs in normal operating environment).

EFC: Provides a drift tracking range of $\pm 10^{-8}$ with no degradation of phase noise or spurious.

Spectral Purity²

Absolute Phase Noise

		Offset from Carrier (Hz)						
		1	10	100	1k	10k	100k	1M
0.1 to 120 MHz	Typ.	-78	-108	-126	-132	-138	-139	-145
	Spec.	-68	-98	-116	-126	-132	-133	
120 to 160 MHz	Typ.	-76	-106	-125	-135	-148	-148	-150
	Spec.	-66	-96	-115	-129	-142	-142	
160 to 320 MHz	Typ.	-70	-100	-119	-130	-142	-144	-144
	Spec.	-60	-90	-109	-124	-136	-138	
320 to 640 MHz	Typ.	-64	-94	-114	-125	-136	-136	-145
	Spec.	-54	-84	-103	-118	-131	-132	
640 to 1280 MHz	Typ.	-58	-88	-108	-119	-130	-130	-140
	Spec.	-48	-78	-97	-112	-124	-126	
1280 to 2560 MHz*	Typ.	-52	-82	-102	-113	-124	-124	-134
	Spec.	-42	-72	-92	-106	-118	-120	

* HP 8663A Option 003 only.

OPTIONS 003 OR 004: ADDING THE HP 11729C OR 11729C OPT 130 CARRIER NOISE TEST SET

The following data is applicable to using the HP 11729C to downconvert the test signal to an IF of between 5 MHz and 1280 MHz for subsequent demodulation using the Low Frequency phase detector of the HP 3048A system. The HP 8662A Opt. 003 or 8663A Opt. 003 Signal Generators provide a 640 MHz reference signal for this downconversion process. These signal generators also provide a signal of between 5 MHz to 1280 MHz to demodulate the downconverted IF noise. The specifications that follow assume this measurement set-up is used.

¹ Measurements < 5 MHz require external phase detector.

² Specified only with FM off.

Input Requirements

Frequency

Measurement Frequency Range: 5 MHz to 18 GHz in 8 bands, excluding ± 5 MHz around band center frequencies.

Band Center Frequencies: 1.92 GHz, 4.48 GHz, 7.04 GHz, 9.60 GHz, 12.16 GHz, 14.72 GHz, 17.28 GHz.

Amplitude

For carrier frequencies < 1.28 GHz: -5 dBm minimum to +23 dBm maximum.

For carrier frequencies > 1.28 GHz: +7 dBm minimum to +20 dBm maximum.

Measurement Specifications

Offset Frequency Range

For carriers between 5 and 95 MHz from band centers: 0.01 Hz to 2 MHz.

For carriers > 95 MHz from band center: 0.01 Hz to 40 MHz.

(Assumes addition of 40 MHz spectrum analyzer to the system, otherwise offset frequency range limited to 100 kHz.)

System Noise Floor³

Absolute System Noise Floor (dBc/Hz), when used with the HP 11729C and HP 8662A Option 003 or HP 8663A Option 003 as the reference source, phase locking via the signal generator's EFC.

		Offset from Carrier (Hz)						
		1	10	100	1k	10k	100k	1M
0.1 to 1280 MHz		See HP 3048A Option 001 or 002, Absolute Phase Noise table on page 13.						
1280 to 3200 MHz	Typ.	-52	-82	-102	-113	-124	-124	-134
	Spec.	-42	-72	-92	-106	-118	-120	
3.2 to 5.76 GHz	Typ.	-47	-77	-97	-109	-127	-130	-138
	Spec.	-37	-67	-87	-104	-123	-126	
5.76 to 8.32 GHz	Typ.	-43	-73	-93	-105	-125	-129	-135
	Spec.	-33	-63	-83	-100	-121	-125	
8.32 to 10.88 GHz	Typ.	-40	-70	-90	-102	-123	-129	-134
	Spec.	-30	-60	-80	-97	-119	-125	
10.88 to 13.44 GHz	Typ.	-38	-68	-88	-100	-122	-128	-132
	Spec.	-28	-58	-78	-95	-118	-125	
13.44 to 16.0 GHz	Typ.	-37	-67	-87	-99	-121	-127	-131
	Spec.	-27	-57	-77	-94	-116	-124	
16.0 to 18.0 GHz	Typ.	-35	-65	-85	-97	-119	-127	-129
	Spec.	-25	-55	-75	-92	-115	-123	

System Noise of HP 3048A Options 001 or 002, and 003 or 004 at 10 GHz (Phase locking via EFC)

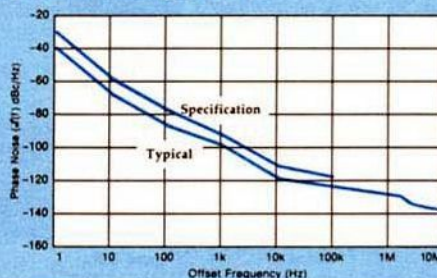

Table 7.2. HP 3048A phase noise measurement specifications.

System Spurious

System spurious signals in the HP 3048A Options 003 or 004 arise in three ways. First, from the detection and baseband signal processing, <-104 dBc for offsets greater than 0.2 Hz from the carrier. Second, any line-related or other spurious signals on the HP 8662A or 8663A outputs are translated to the noise spectrum output. Third, the downconversion process gives rise to system spurious signals whose frequency and level are determined by the relation between the test signal frequency and the band center frequency. The presence of system spurious signals does not affect the typical measurement of random noise.

AM Noise Detection

The HP 3048A can be used for AM noise measurements using either an external AM detector or the AM detector built-in to the HP 11729C Option 130 (ordered as Option 004 of the HP 3048A). AM measurements with the

HP 11729C Option 130 can be made with a typical sensitivity of -165 dBc/Hz at a 1 MHz offset.

COMPATIBLE SPECTRUM ANALYZERS

The HP 3048A is designed to use several Hewlett-Packard spectrum analyzers to extend the offset range from 100 kHz to 40 MHz. Those spectrum analyzers include the HP 3585A (orderable as Option 101 to the HP 3048A), the HP 8566A, 8567A, 8568A, 71100A, and 71200A. Automatic control of each of these spectrum analyzers is provided. The HP 3048A specifications apply fully when these compatible spectrum analyzers are included in the system as long as the spectrum analyzer is operating properly and meets its performance specifications.

Table 7.2.
HP 3048A phase noise measurement specifications.

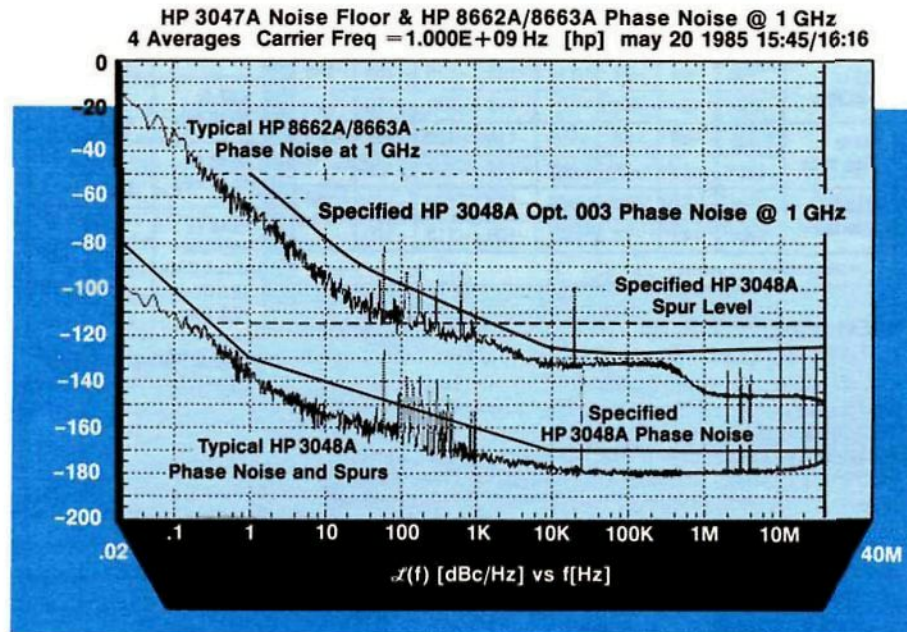

Figure 7.6.
Typical HP 3048A Specified System Noise Floor.

Chapter 8

Voice Grade Receiver Testing with the HP 8662A/8663A

Programmable, low-phase-noise synthesized signal generators are used extensively in receiver testing. The design of the HP 8662A/8663A yields a noise spectrum at typical receiver channel spacings that lends itself readily to receiver test.

The spectral purity of the HP 8662A/8663A is most commonly measured in terms of single-sideband phase noise, but it can also be expressed in terms of residual FM and spurious. Residual FM is the total noise measured in some post-detection bandwidth. Spurious signals are those unwanted signals generated as a result of the various nonlinear operations such as mixing that are part of the synthesis process. These measures of spectral purity are important in defining the performance requirements necessary for a signal generator to make receiver measurements.

There are many receiver tests and many test standards for these measurements used around the world. These include the Institute of Electrical and Electronic Engineers (IEEE) and the Electronic Industries Association (EIA) standards in the United States and the Conference of European Postal and Telecommunications Administration (CEPT), British Post Office (BPO), and International Electrotechnical Commission (IEC) standards in Europe. Though the details of these tests vary considerably, the receiver parameters that must be tested are basically the same.

This chapter describes the two basic categories of receiver testing, the signal generator performance required by them, and how the HP 8662A/8663A meets these test requirements.

Receiver Test Basics: In-Channel and Out-of-Channel Testing

Receiver tests can be roughly subdivided into two basic types: in-channel and out-of-channel. In-channel testing is exactly what the name implies—evaluating the performance of the receiver when the test signal is applied at the exact frequency to which the receiver is tuned. These tests determine how well the receiver responds to the signal that it is intended to receive. An example of this type of test is sensitivity—the smallest level of RF signal applied at the input of the receiver that will give intelligible information at the output. The definition

of ‘intelligible’ information varies with the test standard being used.

Many receiver tests use a calculation called ‘SINAD’ as a measure of the received signal quality. SINAD is equal to the ratio of (signal plus noise plus distortion) to (noise plus distortion) at the same output level; that is,

$$\text{SINAD (dB)} = 20 \log_{10} \frac{S + N + D}{N + D}$$

The measuring instrument at the audio output of the receiver is generally some type of distortion analyzer. For a SINAD measurement, the analyzer first acts as a broadband voltmeter, measuring the total output of the receiver. Then a filter notches out the audio modulation tone, and the resultant noise plus distortion is measured. The ratio of the two measurements is SINAD, and is commonly expressed in dB. The CEPT standard defines sensitivity as that RF input level which produces 20 dB SINAD weighted per CCITT requirements.

Almost all areas of signal generator performance are important for in-channel testing, with the level of performance needed dependent on the receiver being tested. All three primary performance areas—frequency, output level, and modulation—must be considered. The HP 8662A/8663A provides high performance in every specification including frequency resolution, accuracy, and stability; output level resolution and accuracy; and AM or FM with either ac or dc coupled input.

Certain measures of spectral purity can be important for in-channel testing. The low close-in phase noise of the HP 8662A/8663A translates into extremely low residual FM. Typical residual FM in a 300 Hz to 3 kHz post-

detection bandwidth is a few tenths of a hertz. Residual FM can be an important specification for in-channel tests such as receiver residual hum and noise, where the residual FM results in a small amount of detected noise, falsely increasing the measured signal noise.

Out-of-channel testing determines how well the receiver rejects those signals that it is not intended to receive. Here the test signal is applied not at the frequency that the receiver is tuned to but at some other frequency. An example of this kind of test is adjacent channel selectivity, a measure of the ability of the receiver to select the desired in-channel signal while rejecting a signal that is present one channel spacing away.

Out-of-channel testing is more demanding on the test signal generator than in-channel testing. The primary performance requirements needed from the signal generator to make these tests are low spurious and low phase noise at offsets from the carrier equal to the channel spacings of the receiver. An examination of two of these out-of-channel tests shows why.

Using the HP 8662A/8663A for Adjacent Channel Receiver Tests

The adjacent channel selectivity test defined above is one of the most common out-of-channel tests. Two generators are used in this test, one in-channel to simulate the desired signal and the other out-of-channel to simulate an unwanted signal. The following example procedure follows the EIA standard for FM receivers—specification RS-204-B.

Generator #1 produces the in-channel signal, generator #2 the out-of-channel signal (see Figure 8.1). With generator #2

Figure 8.1. Receiver adjacent channel selectivity and receiver spurious attenuation measurement.

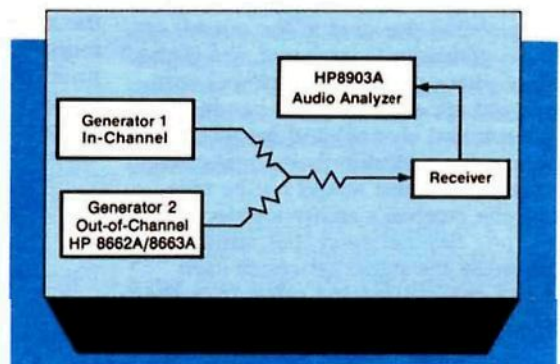

turned off, generator #1 is set in-channel and modulated with a 1 kHz tone at 60% of the maximum rated deviation of the receiver. The level of generator #1 is set to the sensitivity of the receiver (12 dB SINAD for the EIA-FM standard).

Again, the measurement instrument at the audio output of the receiver is generally some type of distortion analyzer. Figure 8.1 shows a Hewlett-Packard Model 8903B Audio Analyzer, which automatically makes the two measurements necessary for a SINAD ratio, then internally calculates and displays SINAD directly in dB. The HP 8903B is fully programmable, allowing the entire test to be automated.

With signal generator #1 set to the sensitivity level of the receiver plus 3 dB, generator #2 is tuned to the adjacent channel of the receiver. It too is modulated at 60% of the receiver's maximum deviation, but with a 400 Hz tone.

The level of generator #2 is then increased until the measured SINAD ratio of the receiver drops to 12 dB as defined in the EIA test standard. This drop in signal quality is a result of interference by the adjacent-channel signal. The difference between the two output settings on the generators is then defined as the receiver's selectivity. The higher the receiver's selectivity, the greater the level of out-of-channel interference it is able to reject.

Phase noise and AM noise are probably the most important specifications which determine whether the signal generator can make an adjacent channel selectivity measurement. Figure 8.2 shows the transfer characteristic of a receiver's IF filter; the selectivity test is designed to show how well the IF filters in the receiver reject signals outside the normal pass-band. If a generator's phase noise or AM noise (even for FM receivers) is inadequate, as the level of the out-of-channel generator is increased, the high level of phase noise at the channel spacing would appear within the bandwidth of the selected channel and would contribute to the distortion being measured. As a result, the test would not be measuring the receiver's ability to reject a signal one channel away, but rather how much noise the signal generator itself had at a channel spacing offset from the carrier.

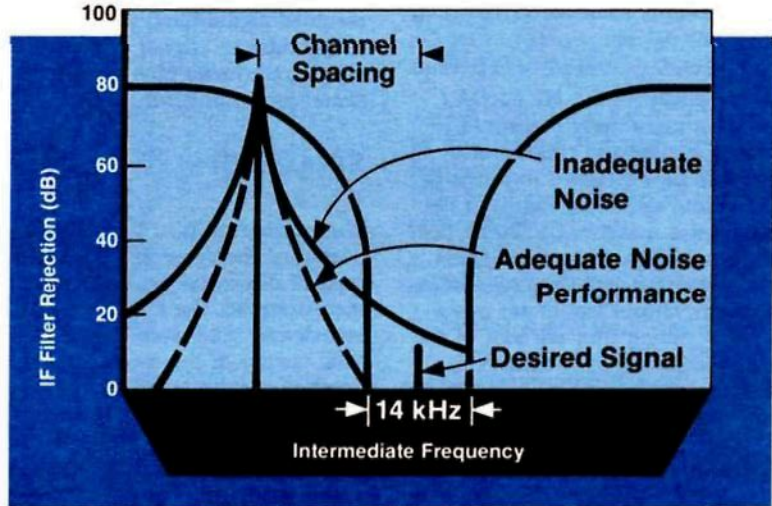
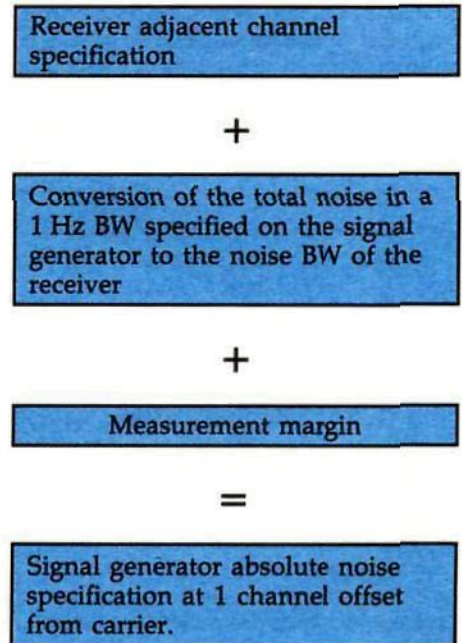

Figure 8.2. Signal generator phase noise in adjacent channel test.

Figure 8.2 shows the noise spectrum of two signals used as the out-of-channel signal. The solid line is an example of a signal generator with inadequate noise performance to make an out-of-channel test; its noise power at a channel offset appears within the bandwidth of the selected channel at a higher level than the desired signal. The dashed line represents a signal with phase noise at a channel spacing low enough to not add significantly to the measured noise within the bandwidth of the selected channel.

To make a valid measurement of the receiver the phase noise performance of the adjacent channel signal generator must be determined. The conversion from the selectivity specification on the receiver to the needed signal generator performance can be easily calculated as shown below.



The first factor is the receiver's adjacent-channel-rejection specification. In the EIA standard, the minimum standard is 70 dB. The second factor is a conversion of the noise of the signal generator, generally specified in a 1 Hz bandwidth, to the equivalent noise in the bandwidth of the receiver under test. For a receiver with a 14 kHz IF bandwidth, this conversion is

$$\text{dB} = 10 \log_{10} \frac{14 \text{ kHz}}{1 \text{ Hz}} = 10(4.2) = 42 \text{ dB}$$

The third factor, measurement margin, is the most arbitrary factor. In the adjacent-channel test, the analyzer measures the noise contributions from two sources: any noise generated by the receiver as a result of the interference of the adjacent channel signal (desired measurement), and the phase noise of the signal generator that falls in-channel (undesired). If, for example, these noise levels are equal, the distortion analyzer will measure noise 3 dB higher than the actual noise generated by the receiver. Measurement margin is added to the phase noise requirement on the out-of-channel generator to ensure that its noise contribution is much less than the noise generated by the receiver. Requiring the phase noise of the signal generator to be lower than the selectivity of the receiver by the amount of the measurement margin yields more repeatable measurements. Experience has shown that 6 to 10 dB measurement margin is sufficient.

These three factors add up to the actual phase noise specification required for the signal generator. For the EIA standard, a 14 kHz BW receiver with an adjacent channel selectivity of 70 dB for channel spacings of 20 kHz requires a signal generator with specified phase noise of $70 + 42 + 10 = 122$ dB below the carrier at a 20 kHz offset from the carrier. It should be noted that this phase noise requirement is for the total or absolute noise on the generator (including AM noise), not the residual noise. For most synthesizers, the absolute noise will be equal to the residual noise at offsets from the carrier equal to channel spacings (20 kHz, for example), but it should be checked for each syn-

thesizer. The difference between absolute and residual noise becomes more pronounced as channel spacings narrow. For a more thorough discussion of absolute versus residual noise, see Chapter 2.

Many high-quality receivers specify a selectivity of greater than the 70 dB for example, requiring even lower phase noise for these out-of-channel applications than the -122 dBc computed above. It is for these high quality receiver test applications that the HP 8662A/8663A makes major contributions. With specified SSB phase noise at a 10 kHz offset from a 500 MHz carrier of -132 dBc (typically -136 dBc), the HP 8662A/8663A has low enough phase noise to automatically make most stringent in-channel and out-of-channel meas-

the frequency spectrum becomes more congested, channel spacings will be narrowed, as exemplified by the 12.5 kHz channel spacings now employed in Europe. For many RF signal generators, the phase noise rises very quickly for offsets from the carrier less than 20 kHz. However, the design of the HP 8662A/8663A yields a phase noise spectrum that remains fairly flat in to about a 7 kHz offset from the carrier. Thus, as channel spacings become closer (5.0 kHz channel spacings are already proposed), the phase noise of the HP 8662A/8663A will still allow automatic out-of-channel receiver testing.

Spurious performance is also an important criterion for the adjacent-channel-selectivity test. If a spurious output from the signal generator

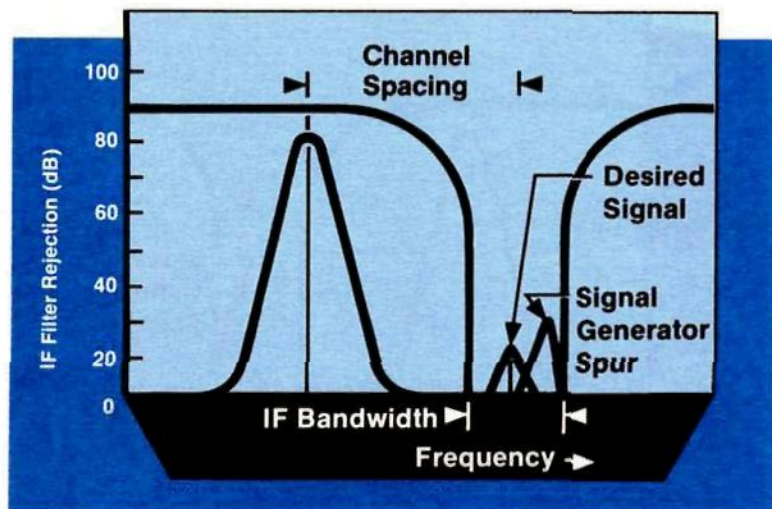

Figure 8.3. Signal generator spurious in adjacent channel test.

urements can be made with the HP 8662A/8663A in a programmable system. For more information on Hewlett-Packard programmable systems for making receiver measurements, see HP Technical Data for the HP 8953A Semi-Automatic Transceiver Test Set and the HP 8955A RF Test System.

Not only can the HP 8662A/8663A automatically make these out-of-channel measurements on receivers with channel spacings of 20 to 50 kHz, but it is also designed for outstanding performance on receivers with narrower channel spacings. As

occurs at an offset from the carrier equal to the receiver channel spacing, the spurious will fall into the receiver IF passband, as shown in Figure 8.3. This will have the effect of reducing the receiver's measured adjacent-channel rejection. To prevent this, non-harmonic spurious generated in the signal generator should be attenuated at least below the receiver's adjacent-channel rejection. The HP 8662A/8663A specifies non-harmonically related spurious to be greater than 90 dB below the carrier in the primary band of 320 to 640 MHz.

Using the HP 8662A/8663A for Spurious Attenuation Testing

A second common out-of-channel test is the spurious attenuation test, a measure of the receiver's ability to discriminate between a desired and an undesired signal. Basically a figure of merit for the input RF filters of the receiver, the test checks if the receiver responds to RF image frequencies, incoming signals at the IF that would feed directly into the audio section, or any other incoming signals that would generate spurious responses within the receiver.

This test, as defined by the EIA (see Figure 8.1), uses two signal generators. Generator #1 is tuned to the nominal frequency of the receiver and set to the receiver sensitivity level plus 3 dB. Generator #2 is tuned to

ous responses of the receiver from spurious outputs of the generator. As shown in Figure 8.4, if a spurious output from the signal generator falls into the receiver IF pass-band, it will have the same effect as a spurious response in the receiver itself. Therefore, spurs generated in the signal generator should be attenuated at least below the level of the receiver's own spurious attenuation. The low spurious output of the HP 8662A/8663A minimizes the possibility of causing what would appear to be spurious response of the receiver.

Broadband noise floor is a second aspect of spectral purity that is important for this test. Figure 8.5 shows a large out-of-channel signal "punching through" the IF filter (that is, at a level high enough to exceed the IF

rejection), thereby introducing a spurious response in the receiver seen in the IF passband. It is this spurious response that the spurious attenuation test is designed to measure. However, if the signal generator has a high broadband noise floor, the spurious response of the receiver will be masked by the noise of the generator. The phase noise of a signal generator is generally specified in a 1 Hz bandwidth. With a 14 kHz receiver bandwidth, the noise seen by the receiver is $10 \log(14 \text{ kHz}/1 \text{ Hz})$ or 42 dB higher. If the receiver has very good spurious attenuation, the generator must have a very low broadband noise floor. If not, as the RF level of the generator is increased, that part of the generator's noise floor that falls within the tuned bandwidth of the receiver will actually be seen before spurious generated in the receiver, causing the output to always be noisy (Figure 8.5).

The HP 8662A/8663A specifies a broadband noise floor of -145 dBc per Hz (-148 dBc/Hz typical) for f_c between 120 and 640 MHz. This noise in a 14 kHz receiver bandwidth will be 42 dB higher, or -108 dB below the carrier, which is sufficient performance for most high quality receivers specifying 90 or 100 dB spurious attenuation.

Combining outstanding RF specifications, excellent spectral purity, and ease of programming, the HP 8662A/8663A provides all the performance necessary to automate the whole range of receiver tests, both in-channel and out-of-channel.

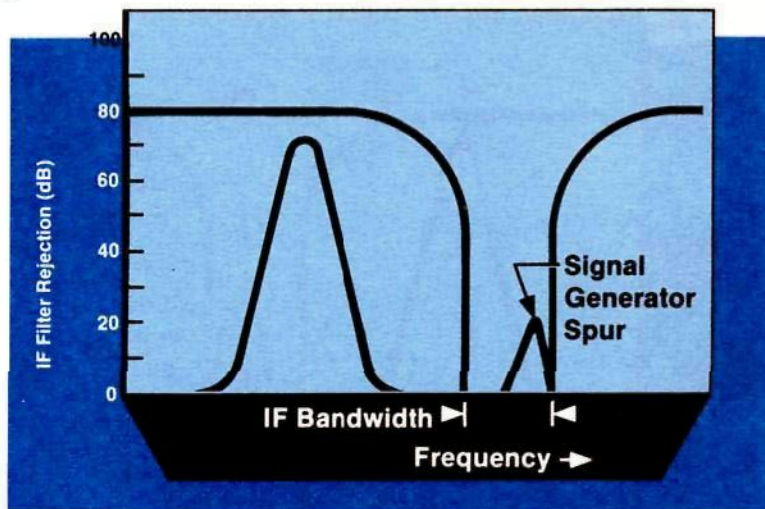

Figure 8.4. Signal generator spurious in spurious attenuation test.

the adjacent channel frequency of the receiver and set to a very high level (90 dB μV for example). Signal generator #2 is then tuned over the frequency range of the receiver, as well as the IF and image frequencies. If a response is observed the output level of generator #2 is varied until the measured SINAD ratio of the receiver is 12 dB, as defined in the EIA test standard. The difference in output levels between the two signal generators is the Spurious Response Attenuation.

The spurious output of the signal generator is critical for this test because the analyzer cannot distinguish spuri-

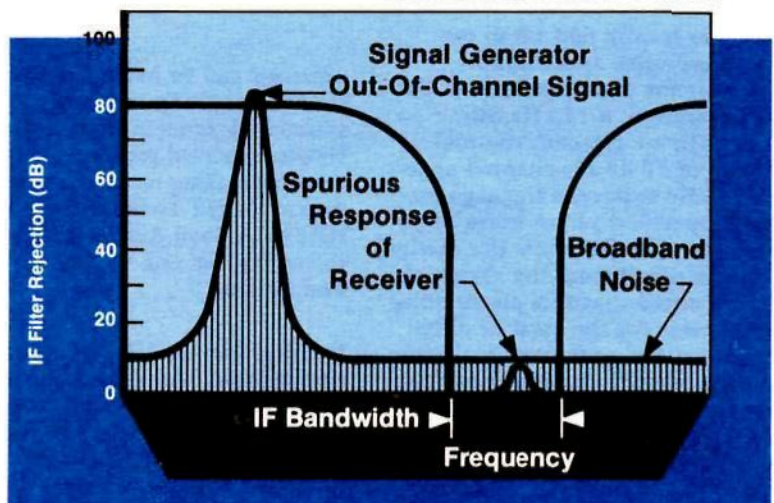

Figure 8.5. Broadband noise floor in spurious attenuation test.

Chapter 9

HP 8662A/8663A as an External LO with the HP 8901A/B Modulation Analyzer and HP 8902A Measuring Receiver

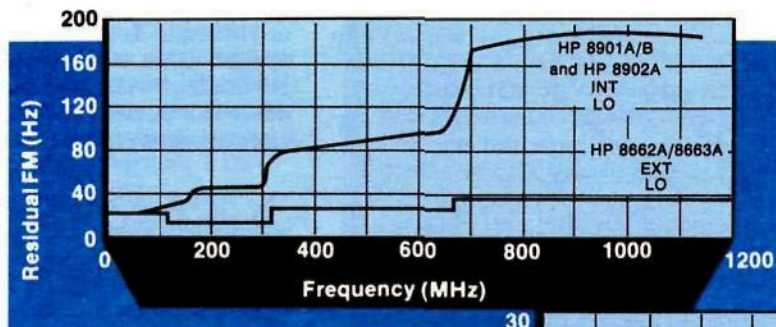

Figure 9.2.
HP 8901A/B and HP 8902A typical residual FM with no filtering.

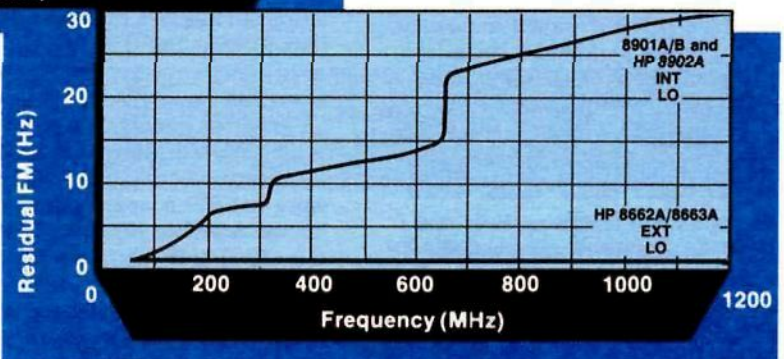

Figure 9.3.
HP 8901A/B and HP 8902A typical residual FM with 15 kHz LPP.

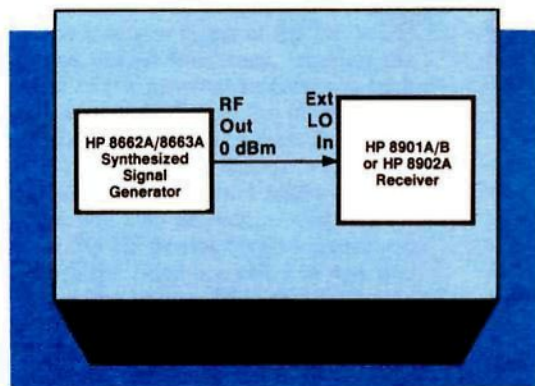

Figure 9.1.
HP 8662A/8663A as external local oscillator for HP 8901A/B or HP 8902A.

The HP 8662A/8663A can be used as a low noise substitute local oscillator (LO). In this application, it can significantly improve the stability and performance of other instruments and measurement systems. In particular, the HP 8662A/8663A can be used with the Hewlett-Packard 8901A/B Modulation Analyzer and HP 8902A Measurement Receiver to improve residual FM.

The HP 8901A/B and HP 8902A are calibrated receivers that measure modulation (AM, FM, ϕ M), frequency, and power automatically for input frequencies from 150 kHz to 1300 MHz. The HP 8901A/B and HP 8902A feature low noise local oscillators; therefore, low residual FM is one of the key contributions. However, for some applications—measuring hum and noise on FM mobile transmitters, for example—even lower noise performance may be desired. Option 003 allows the HP 8901A/B and the HP 8902A to accept an external local oscillator signal for improved stability and noise performance.

Measured Performance

Figure 9.1 shows how to connect the HP 8662A/8663A as the external LO. Figures 9.2 and 9.3 show typical HP 8901A/B and HP 8902A residual FM performance using first the internal receiver LO, and then the HP 8662A/8663A as the external LO. The noise when the HP 8662A/8663A is used is as much as an order of magnitude lower than when the internal local oscillator is used.

Figure 9.2 shows typical receiver residual FM performance without any internal filtering. Notice that above 640 MHz the HP 8662A/8663A improves the noise by greater than a factor of 4, reducing the residual FM to ≤ 40 Hz. Using the receivers internal 15 kHz low-pass filter (Figure 9.3) with the HP 8662A/8663A as an external LO the typical residual noise is less than 3 Hz across the entire frequency range, as compared to ≤ 30 Hz with the internal LO.

Notice the effect of frequency on the residual FM of the receiver. The HP 8901A/B and HP 8902A's internal LO operates from 320 to 650 MHz. All

other frequency ranges are obtained by dividing or multiplying this base band. Therefore the residual noise for $f_c > 650$ MHz is approximately twice that for $320 \text{ MHz} < f_c < 650 \text{ MHz}$. (For a discussion of the effect of multiplication or division on the noise of a signal, see Chapter 7, "Using the HP 8662A/8663A at Microwave Frequencies with the HP 3048A Phase Noise Measurement System".)

The same effect occurs when the HP 8662A/8663A is used as the external LO for analogous reasons. The HP 8662A/8663A's main band is 320 to 640 MHz. Frequencies from 640 to 1280 MHz are obtained by doubling; as a result, the noise in this doubled band is approximately twice that of the base band. Frequencies from 160 to 320 MHz are in the divide-by-2 band; 120 to 160 MHz is the divide-by-4 band. The noise in these bands is therefore one-half and one-fourth that of the main band. Frequencies from 0.01 to 120 MHz are obtained by heterodyning the fundamental band, yielding noise performance similar to the noise of the 320 to 640 MHz range.

Measurement Considerations and Procedure

When the HP 8662A/8663A is used as an external LO for the receivers there are several considerations to take into account. Using an external LO requires that the internal LO be essentially disabled, so that it does not wander and introduce spurious signals into the measurement. This can be accomplished by manually tuning the HP 8901A/B or HP 8902A's LO to a known frequency. Tuning it to the high end is acceptable except when the application is at the upper frequency limit of the receiver. To fix the internal LO at the high end, key in



In frequency mode, the receiver measures input frequency automatically by first counting the internal local oscillator and then the intermediate frequency (IF). The input frequency F_{IN} is then calculated from $F_{IN} = F_{LO}(\text{receiver}) - F_{IF}$. When the HP 8662A/8663A is used as an external LO, the receiver's internal LO is manually fixed at 1300 MHz; consequently, the standard frequency measurement is invalid. The receiver can still, however, indirectly count the incoming frequency. Keying



into the receiver keyboard sets up the HP 8901A and keying



sets up the HP 8901B and HP 8902A to measure the signal frequency being amplified in the IF (F_{IF}). Then the input frequency can be externally calculated from

$$F_{IN} = F_{8662A/8663A} - F_{IF}$$

The receivers operate with two IF frequencies—1.5 MHz and 455 kHz. The HP 8662A/8663A must be manually set to the proper offset frequency to produce one of these intermediate frequencies in the receiver. In normal operation, it is recommended that the HP 8662A/8663A always be set such

that $F_{8662A/8663A} > F_{IN}$. Set the HP 8662A/8663A to $F_{IN} + 455$ kHz for input frequencies from 2 to 10 MHz. For frequencies > 10 MHz, the HP 8662A/8663A should be set to $F_{IN} + 1.5$ MHz. For increased sensitivity the 455 kHz IF may also be selected for input frequencies above 10 MHz, but modulation rates and FM deviations are restricted.

Since the receiver cannot count the input signal unless the IF is in the proper range, the input frequency must be known to within the IF bandwidth in order to set the HP 8662A/8663A to the proper LO frequency. For most transmitter measurements, this is not a problem, since the BW is approximately ± 1 MHz for the 1.5 MHz IF, and ± 100 kHz for the 455 kHz IF. Once the difference between the input signal and the HP 8662A/8663A LO frequency is within the IF bandwidth, the receiver can be used to count the incoming frequency with increased resolution. Then the HP 8662A/8663A can be offset by exactly the IF center frequency for optimal performance.

A convenient way to offset the HP 8662A/8663A by the proper IF frequency is to use the HP 8662A/8663A Special Function 11, "+ Frequency Offset". Special Function 11 makes the actual HP 8662A/8663A output frequency equal to the sum of the frequency shown on the display and the entered offset. Then only the desired signal frequency need be entered into the HP 8662A/8663A, and the necessary frequency offset will be obtained transparent to the operator. For example, if the 1.5 MHz IF is desired, key into the HP 8662A/8663A:

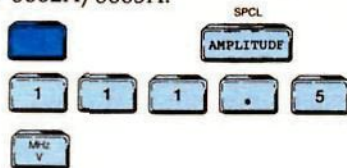

For measurements on the HP 8901A/B or HP 8902A key in the frequency to be applied to the receiver into the HP 8662A/8663A keyboard. The IF offset will be set without any external calculations on the part of the user.

The HP 8662A/8663A can be used as an external LO to improve receiver noise performance. For more information on the HP 8901A/B and HP 8902A, see HP 8901A Technical Data Sheet and HP Application Note 286-1, Applications and Operation of the HP 8901A Modulation Analyzer, HP 8901B Technical Data Sheet, and HP 8902A Technical Data Sheet.

Chapter 10

Using an HP 8662A/8663A with the HP 8505A RF Network Analyzer

Network analyzers measure device transmission and reflection characteristics in terms of magnitude and phase. A key component of a network analyzer is the signal source. When devices are characterized as a function of frequency, particularly over a broad frequency range, sweep oscillators are commonly used as the signal source. For measurements on narrowband devices, or devices whose magnitude and/or phase characteristics change rapidly with frequency, signal generators or synthesizers are preferred because of improved residual FM and frequency resolution.

The Hewlett-Packard Model 8505A RF Network Analyzer Option 005 allows the HP 8505A to be phase-locked to a synthesizer, thus improving frequency accuracy and stability. The low phase noise performance of the HP 8662A/8663A makes them an excellent choice for use as the HP 8505A source. When used with an HP 8662A/8663A in the phase-lock mode, the HP 8505A provides crisp CRT displays and high resolution digital readouts of transmission magnitude and delay over swept frequency widths ranging from only a few hertz to 1 megahertz. In addition to transmission magnitude and delay measurements, the HP 8505A can provide calibrated displays of return loss, reflection coefficient, phase, and phase deviation over its 500 kHz to 1.3 GHz frequency range. The HP 8662A/8663A provide 0.1 or 0.2 hertz center frequency resolution.

Measurement Setup

The HP 8662A/8663A can be configured with the HP 8505A Option 005 in one of

two ways, depending on the desired measurement. Figure 10.1 shows how to set up the HP 8662A/8663A with the HP 8505A Option 005 for making transmission magnitude and delay measurements. The system can also be configured for return loss and reflection coefficient measurements. For detailed instructions on these setups refer to the Operating and Service Manual for the HP 8505A Network Analyzer Option 005 Phase-Lock, Option Supplement Chapter F, Supplement Part Number 08505-90070.

In either setup, the HP 8505A generates a maximum ramp voltage of $\pm 1.3V$ (the $\pm \Delta F$ output of the HP 8505A) used to externally frequency modulate the HP 8662A/8663A and provide a real-time, stable, calibrated swept display on the HP 8505A. Whenever an external source is used with the HP 8505A Option 005, it is necessary to calibrate the modulation index of the phase-locked system in order to obtain an accurate measurement of group delay and to allow easy and exact settings of sweep width. This is essentially a calibration of the external source frequency deviation.

The external frequency modulation of the HP 8662A/8663A simplifies this calibration. The external modulation input of the HP 8662A/8663A requires a 1V peak signal, the $\pm \Delta F$ output of the HP 8505A is easily adjusted to this level. Calibration of the system is accomplished with the two front panel annunciators of the HP 8662A/8663A which indicate when the 1V peak signal is within $\pm 2\%$. Simply key in the desired frequency deviation on the HP 8662A/

8663A (which is the desired sweep width on the HP 8505A) and adjust the $\pm \Delta F$ output of the HP 8505A until the "HI-LO" annunciators on the front panel of the HP 8662A/8663A remain extinguished. The deviation and thus the display is then calibrated and accurate to the specification of the HP 8662A/8663A. For standard operation of the HP 8505A, these deviations will be ± 1.3 kHz (13 MHz range), ± 13 kHz (130 MHz range) and ± 130 kHz (1300 MHz range). For additional flexibility in range and resolution, the HP 8662A/8663A can be set to produce other peak deviations, where the maximum range and resolution are computed by the formulas below. The frequency deviation will retain its specified accuracy as long as the required 1V peak signal is applied.

The HP 8662A/8663A provide for both ac and dc coupling of the external FM input. For very narrowband devices, the DC-FM mode will normally be selected, as slow sweep speeds on the HP 8505A are required. Center frequency stability of the HP 8662A/8663A is somewhat degraded in the DC-FM mode (see HP 8662A/8663A Technical Data Sheets for specifications).

For other applications, ac mode, which allows rates down to 20 Hz is acceptable, yielding higher frequency stability ($\pm 5 \times 10^{-10}$ /day stability).

Maximum Range =

$$\frac{1.04 \times 10^5}{(\pm \Delta F)} \mu S$$

Maximum Resolution =

$$\frac{130}{(\pm \Delta F)} \mu S/DIV$$

Typical Operating Characteristics

The HP 8662A/8663A improves the performance of the HP 8505A Network Analyzer. The following sections describe typical performance of a phase-locked system using the HP 8662A/8663A with the HP 8505A Option 005.

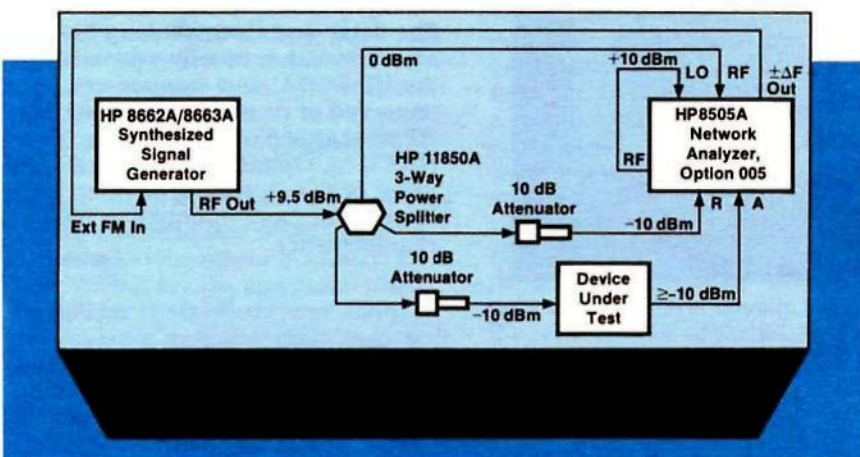

Figure 10.1.
HP 8505A phase-lock test setup with HP 8662A/8663A.

Frequency Characteristics Range and Resolution

HP 8505 Frequency Range	0.5 to 13 MHz	0.5 to 130 MHz	0.5 to 1300 MHz
CW Resolution (set on HP 8662A/8663A)	0.1 Hz	0.1 Hz	0.2 Hz
$\pm\Delta F$ Resolution (set on HP 8505A)	1 Hz	10 Hz	100 Hz

Table 10.1
HP 8505A frequency characteristics when locked to HP 8662A/8663A.

NOTE: The maximum $\pm\Delta F$ is limited by maximum FM peak deviation allowed on the HP 8662A/8663A at the frequency of interest. For example, for frequencies $0.5 < f < 13$ MHz, the HP 8662A/8663A has specified deviations to 100 kHz. Therefore, a $\pm\Delta F$ of 100 kHz can be used at the 13 MHz range of the 8505A, provided group delay and electrical length readings are rescaled. Maximum FM peak deviations of the HP 8662A/8663A are listed in Table 10.2 below.

Center Frequency (MHz)	Maximum Peak Deviation	
	ac Mode (kHz)	dc Mode (kHz)
0.01/0.1—120	The smaller of: 100 or $f_{\text{mod}} \times 500$	100
120—160	25 or $f_{\text{mod}} \times 125$	25
160—320	50 or $f_{\text{mod}} \times 250$	50
320—640	100 or $f_{\text{mod}} \times 500$	100
640—1280	200 or $f_{\text{mod}} \times 1000$	200
1280—2560*	400 or $f_{\text{mod}} \times 2000$	400
*HP 8663A only.		

Table 10.2.
Specified HP 8662A/8663A FM deviation.

Typical system residual FM

The total phase noise of the signal source used with the HP 8505A translates into residual FM. Residual FM limits the rate at which the phase or frequency of the device under test can change and still maintain a stable display. The residual FM of a phase-locked HP 8505A approaches that of the HP 8662A/8663A, which is less than 0.1 Hz, allowing very sharp filter skirts to be measured.

Output characteristics

Output power, harmonics, spurious, and phase noise of the system are determined by the HP 8662A/8663A. The phase noise of the source used with the HP 8505A also affects the measurement capability. In the measurement of a narrow bandwidth notch filter, the filter may attenuate the carrier but pass noise several kilohertz from the carrier with practically no attenuation. If the noise 200 kHz from the carrier mixes with the HP 8505A local oscillator (LO frequency = RF frequency ± 100 kHz) to produce a 100 kHz IF response < -110 dBm, the response will "fill in" the notch, making the attenuation of the notch appear less than its true value. This can effectively limit the dynamic range of the HP 8505A. The low SSB phase noise of the HP 8662A/8663A minimizes this effect. The SSB phase noise at a 200 kHz offset from the carrier is typically < -136 dBc ($F_c = 500$ MHz), reducing the possibility of mixing with the LO of the HP 8505A.

Delay and electrical length characteristics

The delay and electrical length characteristics are primarily a function of the HP 8505A, and thus are not improved or degraded by use of the HP 8662A/8663A. Refer to the HP 8505A Option 005 Technical Data Sheet or the Operating and Service Manual for more information on these characteristics.

Chapter 11

Using the HP 8662A/8663A as a Substitute LO with the HP 8672A Microwave Synthesized Signal Generator

The low phase noise of the HP 8662A/8663A makes it an ideal substitute local oscillator. It is also an excellent substitute for a variable oscillator such as a voltage controlled oscillator (VCO) as it is tunable over a wide range of frequencies. The HP 8662A/8663A can therefore be used as a substitute VCO inside the Hewlett-Packard Model 8672A or 8673A Microwave Synthesized Signal Generator to improve the HP 8672A/8673A phase noise performance and frequency resolution over their 2-to-18 or 2-to-26 GHz frequency range.

System Operation

The HP 8672A is a microwave synthesized signal generator that derives its output frequency from four phase-lock loops (Figure 11.1). The LFS (Low Frequency Section) loop determines the four

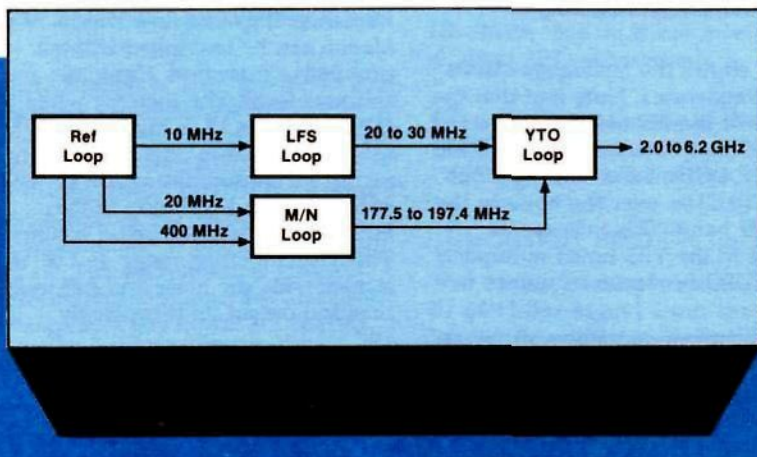

Figure 11.1.
HP 8672A phase-lock loops.

least significant digits of the output frequency, while the M/N loop generates the higher-order digits. The outputs from these two loops are inputs to the YTO (YIG-tuned oscillator) loop, a sum loop that translates these inputs directly to microwave frequencies.

Within the bandwidth of a phase-lock loop, the output VCO noise tracks the noise of the reference. In a sum loop, such as the YTO loop in the HP 8672A, where two frequencies are used as references, the output VCO noise tracks the sum of the noise of the two references.

In the HP 8672A, the noise on the output of the M/N loop is the primary contributor to the phase noise of the final output signal. As indicated in the block diagram of the YTO loop

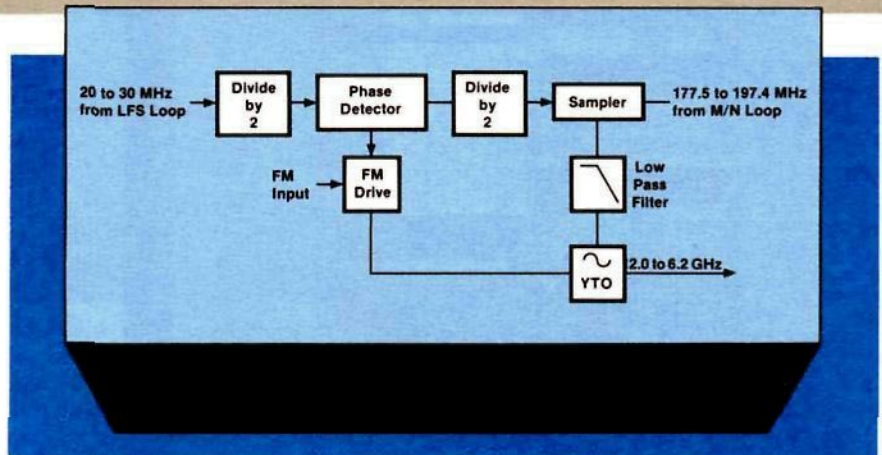

Figure 11.2.
HP 8672A YTO loop.

(Figure 11.2), the output frequency of the M/N loop (177.5 to 197.4 MHz) is multiplied up to microwave (2 to 6.2 GHz) by a harmonic mixing process. The sampler

Within the bandwidth of the YTO loop, the noise of the YTO tracks the phase noise of the multiplied signal from the M/N loop. If a very low phase noise signal is substituted for the output of the M/N loop, the improvement in phase noise is translated to the output. Substitution of the HP 8662A/8663A for the M/N loop frequency yields the excellent close-in phase noise performance of the HP 8662A/8663A within the YTO bandwidth (approximately 10 kHz) while still providing good broadband noise performance at greater offsets from the carrier.

Hardware Modifications

The necessary modifications to the HP 8672A are easy to do. They involve simple cable re-routing to substitute a signal from the HP 8662A/8663A for the M/N loop frequency in the HP 8672A. Refer to the interior layout photo of the HP 8672A (Figure 11.3) for location of the necessary cabling.

1. Disconnect green cable from J1 of A2A3.
2. Disconnect cable from "20 MHz OUT" of Reference Loop.
3. Reconnect the green cable that previously went to J1 of A2A3 to the "20 MHz OUT" of Reference Loop.
4. Disconnect the orange/white cable from "M/N OUT" and reconnect it to the HP 8662A/8663A RF output jack.
5. Set the HP 8662A/8663A output level to +4 dBm.
6. Connect the 10 MHz Reference Output from the rear panel of the HP 8662A/8663A to the HP 8672A External Reference Input.
7. Select EXT REF on the rear panel of the HP 8672A.

generates harmonics of the output of the M/N loop and mixes them with the microwave output of the YTO to generate a 20 to 30 MHz difference signal. The 20 to 30 MHz output of the sampler thus has the phase noise of the microwave signal generated by multiplying the 177.5 to 197.4 MHz signal. The phase noise on the 20 to 30 MHz output from the LFS loop is added to the noise on this microwave signal, but the noise on the 20 to 30 MHz signal is at a much lower level, as it is generated by effectively multiplying the 10 MHz reference signal by a factor of only 2 to 3. Compared to the noise on the signal at microwave frequencies, this noise contribution is negligible. For more information on the block diagram of the HP 8672A, see Hewlett-Packard Application Note 218-1, "Applications and Performance of the 8671A and 8672A Microwave Synthesizers."

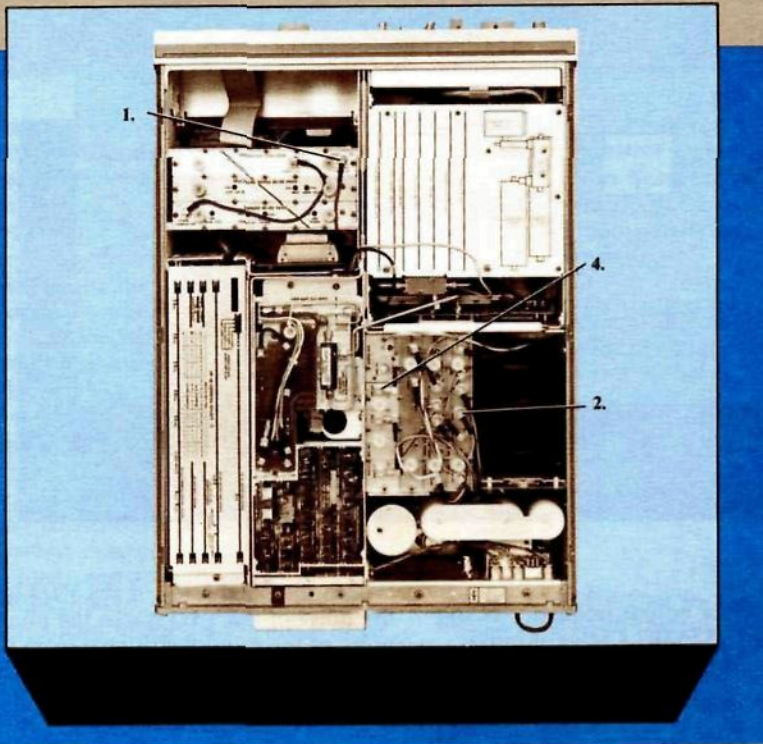

Figure 11.3.
HP 8672A A2A3 board.

SYSTEM PERFORMANCE

Spectral Purity

Figure 11.4 shows the measured absolute SSB phase noise of the HP 8672A at 6 GHz using its internal M/N loop and the phase noise with the HP 8662A/

8663A substituted for this loop. Note that the close-in phase noise is improved as much as 20 dB by substituting the HP 8662A/8663A. The data also shows the relationship between the bandwidth of the YTO phase-lock loop and the resultant phase noise. For offsets greater than the bandwidth of the YTO loop (about 10 kHz), the measured phase noise follows the typical phase noise of the HP 8672A.

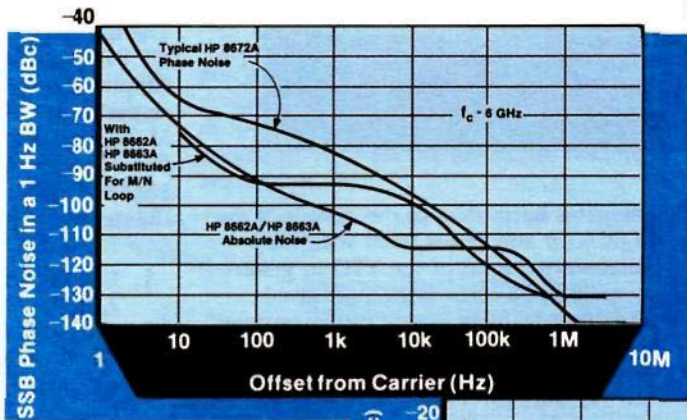

Figure 11.4.
Effect of HP 8662A/8663A substitution on HP 8672A phase noise at 6 GHz.

8663A substituted for this loop. Note that the close-in phase noise is improved as much as 20 dB by substituting the HP 8662A/8663A. The data also shows the relationship between the bandwidth of the YTO phase-lock loop and the resultant phase noise. For offsets greater than the bandwidth of the YTO loop (about 10 kHz), the measured phase noise follows the typical phase noise of the HP 8672A.

frequency. Similarly, phase noise using the HP 8662A/8663A in place of the M/N loop frequency increases for the higher output frequencies.

Also plotted in Figure 11.4 is the typical phase noise of the HP 8662A/8663A multiplied directly to 6 GHz. Note that a microwave signal generated in this manner has even better close-in phase noise performance, but the broadband noise is degraded. (For more information on how to multiply and use the HP 8662A/8663A at microwave frequencies see Chapter 7). For some applications where the lowest possible phase noise is desired, a multiplied HP 8662A/8663A is the best solution. However, this method of obtaining a microwave signal sacrifices some of the benefits of using a signal generator—calibrated and variable output level, for example. Multiplication also severely limits AM performance; only very low depths of modulation can be multiplied without prohibitive distortion. Harmonic and spurious levels also increase when the HP 8662A/8663A is multiplied. When these performance parameters cannot be sacrificed, substitution of the HP 8662A/8663A for the M/N loop in the HP 8672A provides a better solution. This yields a broad range of 2 to 18 GHz signals with low noise and full modulation and output level capability.

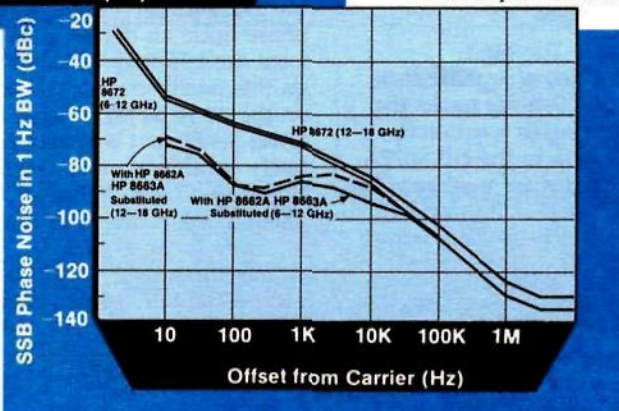

Figure 11.5.
Effect of HP 8662A/8663A substitution on HP 8672A phase noise at 18 GHz.

Resolution

The standard frequency resolution of the HP 8672A is 1 to 3 kHz, depending on output frequency band. Though this is sufficient for most applications, substituting the HP 8662A/8663A for the M/N loop also results in increased resolution. The frequency resolution varies with output frequency, and is a function of two factors: 1) the harmonic of the HP 8662A/8663A that must be mixed with the 2 to 6.2 GHz output of the YTO to yield a 20 to 30 MHz difference signal, and 2) the band the HP 8672A is operating in. To determine the resolution it is necessary to examine the frequency algorithm.

Frequency Algorithm

For a desired HP 8672A output frequency the necessary 177.5 to 197.4 MHz signal from the HP 8662A/8663A and HP 8672A setting can be readily calculated. First, the output band of the desired HP 8672A signal must be determined. The fundamental frequency band of the HP 8672A is 2.0 to 6.2 GHz, the range of the YTO in the block diagram of Figure 11.1. The other frequency bands are obtained with a YIG-tuned multiplier, selecting either the second or third harmonic of the fundamental band. Let F be the desired frequency in MHz and B , the output frequency band of the HP 8672A, where

$$B = \begin{cases} 1, & 2 < F < 6.2 \text{ GHz} \\ 2, & 6.2 < F < 12.4 \text{ GHz} \\ 3, & 12.4 < F < 18.6 \text{ GHz} \end{cases}$$

Then the frequency that the YTO must tune to is

$$F_{YTO} = \frac{F}{B}$$

This YTO frequency requires an N in the M/N loop of

$$N = \text{INT} \left[\frac{F_{YTO} + 300}{200} \right]$$

where $\text{INT}(X)$ is the integer value \leq the value of X .

The necessary HP 8662A/8663A frequency is then

$$F_{8662A/8663A} = \left[\frac{F_{YTO} + 20}{N} \right]$$

and the HP 8672A should be set to

$$F_{8672A} = \text{INT} \left[\frac{F}{10} \right] \times 10$$

Note: All above frequencies have units of MHz.

The output resolution will then be equal to

$$(\text{resolution of HP 8662A/8663A}) \times N \times B$$

As an example, if the desired HP 8672A output frequency is 10.5 GHz, $B = 2$, $F_{YTO} = 10.5/2 = 5.25$ GHz. Then $N = \text{INT} [(5250 + 300)/200] = \text{INT} (27.75) = 27$. The HP 8662A/8663A should therefore be set to

$$F_{8662A/8663A} (\text{MHz}) = \frac{5250 + 20}{27} = 195.1851852 \text{ MHz}$$

and the HP 8672A tuned to

$$F_{8672A} (\text{MHz}) = \text{INT} \frac{10500}{10} \times 10 = 10500 \text{ MHz}$$

The resolution of this output signal is $0.1 \text{ Hz} \times 27 \times 2 = 5.4 \text{ Hz}$.

Note: When the HP 8672A is operated in this mode, the "not phase-locked" annunciator on the HP 8672A remains on. This is because the M/N loop is unlocked, but this loop is not used to derive the HP 8672A output frequency. The signal at the HP 8672A output port is phase-locked if the "REF LOOP", "YTO LOOP", and "LFS LOOP" LED's are glowing on the HP 8672A A2A7 Interface Assembly Board and if the HP 8662A/8663A does not display a hardware status message.

Modulation

This configuration also allows the HP 8672A to have increased modulation capability. The standard modulation capability of the HP 8672A remains unchanged, but the modulation performance of the whole system can be expanded by modulating the 177.5 to 197.4 MHz signal. A standard HP 8672A's FM is limited by modulation index: m must be less than 5 for carrier frequencies from 2 to 6.2 GHz,

less than 10 from 6.2 to 12.4 GHz, and less than 15 from 12.4 to 18 GHz. However, because any frequency modulation on the 177.5 to 197.4 MHz signal is translated with the signal up to microwave frequency by the YTO loop, it is possible to frequency modulate the carrier with a very high modulation index.

It is possible to FM at rates up to the YTO loop bandwidth, approximately 10 kHz. Frequency modulation is limited by the ability of the YTO loop to respond, and at low rates peak deviations in excess of 1 MHz are possible (Figure 11.6). Switching the HP 8672A to the FM mode (with no modulation input to the HP 8672A) allows the FM OVERMOD indicator on the front panel to be used to determine if the frequency deviation applied to the 177.5 to 197.4 MHz signal is so large the YTO loop cannot respond properly. For modulation applied to the substituted M/N loop frequency, there is no FM meter indication on the HP 8672A.

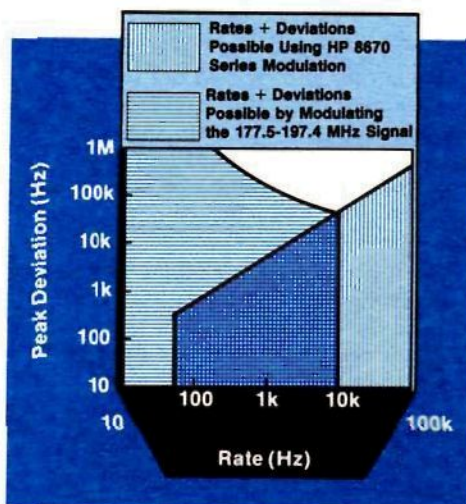

Figure 11.6. Increased FM performance with HP 8662A/8663A substitution.

The HP 8662A/8663A for output frequencies between 177.5 and 197.4 MHz allows peak deviations up to the smaller of 50 kHz or up to $f_{\text{mod}} \times 250$. However, the frequency deviation set on the HP 8662A/8663A gets translated up in the YTO loop. The HP 8672A deviation is then equal to the deviation set on the HP 8662A/8663A $\times N \times B$. For low rates, this yields frequency modulation with a very high modulation index.

Chapter 12

Fast Frequency Switching with the HP 8662A/8663A

The combination of low noise and fast frequency switching is unusual and difficult to achieve in synthesized signal generator design. The HP 8662A and HP 8663A optimize these conflicting design requirements providing excellent SSB phase noise, as discussed in the previous chapters, and frequency switching as fast as 420 μ sec for the HP 8662A and 510 μ sec for the HP 8663A, to be within 100 Hz accuracy.

Standard HP-IB Frequency Control

An understanding of the standard HP-IB frequency control of the HP 8662A/8663A is helpful for programming and utilizing the fast frequency switching capabilities of the instrument. In the normal operating mode of the HP 8662A/8663A, programming a specific frequency is accomplished in a three step process. First a string of binary frequency data is sent to the instrument over the HP-IB. Secondly, the instrument microprocessor operates on this string breaking it into binary data segments necessary to control the phase locked loops and output circuitry. This processed binary data is sent to the frequency control board where it is loaded into latches and clocked out to the instrument to set the frequency of the output signal. In the third step of the process the phase locked loops and output circuitry switch and settle to the desired final frequency.

The last two steps contribute to a total switching time of 12.5 milliseconds. Since the time contribution from the first step is determined by the external controller it will not be discussed. The dominant contributor to instrument switching time is step two, the data processing time of the microprocessor. This consumes approximately 12.1 msec. During this time, the microprocessor does two things to the frequency control data. It scales the desired frequency to a frequency in the fundamental band of the instrument and selects the range information necessary to transform the fundamental frequency to the desired output frequency. The scaled frequency data is necessary for the phase locked loops to synthesize the correct fundamental frequency (320 to 640 MHz in .1 Hz steps), as discussed in Chapter 3. The range information is necessary for the output section to select the correct means of translating that fundamental to the desired frequency, either by multiplying, dividing, or heterodyning, if it

does not already lie in the fundamental band. For example, to output a frequency of 100 MHz, the microprocessor scales the frequency to the fundamental band by adding 520 MHz. A 620 MHz signal is synthesized in the PLL section and sent to the output section. Range data representing the 10 to 120 MHz range alerts the output section that the desired frequency is in the heterodyne band and switches in the output section mixer. Table 12.1, Frequency Scaling and Ranging, lists desired output frequency, the corresponding fundamental frequency, the scaling factor to get from the desired frequency to the fundamental band, and the appropriate range information.

Overall switching time is depicted in Figure 12.1 Typical Frequency Switching Times. The microprocessor time to scale and range the frequency command is the dominant contributor, and switching and settling time add approximately 420/510 μ sec to settle to within 100 Hz. Depending on the switching accuracy required, switching and settling time can be as fast as 250 μ sec for settling to within 1 kHz. As can be seen from the graph, substantial improvement in switching speed can be achieved by eliminating the microprocessor time.

Fast Learn Frequency Switching

The fast learn mode eliminates HP 8662A/8663A data interpretation time by providing a means for an external controller to "learn" the appropriate binary data segments in advance. Outputting only the binary frequency data and bypassing the instrument microprocessor significantly decreases switching time of the synthesizer. Settling time becomes the determinant switching speed factor, settling time being primarily due to the response and transient settling time of the phase locked loops. In the fast learn mode, switching times of 420/510 μ sec are possible for the HP 8662A/8663A with the majority of this time attributed to instrument settling to within 100 Hz.

To eliminate the microprocessor time of the HP 8662A/8663A binary data is sent via HP-IB that has already been ranged and scaled to the fundamental band of the instrument. Processing the frequency command beforehand allows strings of frequency data to be output to the instrument and executed immediately. The data string for the fast learn mode consists of 11 characters for the HP 8662A and 16 characters for the

Table 12.1
Frequency Scaling and Ranging

Desired Output Frequency (MHz)	Fundamental Frequency (MHz)	Scaling Factor	Frequency Range (MHz)
.1 to 119.999999	520.1 to 639.999999	+520 MHz	.1 to .15 .15 to 1 1 to 10 10 to 120
120 to 159.999999	480 to 639.999996	$\times 4$	120 to 160
160 to 319.999999	320 to 639.999998	$\times 2$	160 to 200 220 to 320
320 to 639.999999	320 to 639.999999	$\times 1$	320 to 450 450 to 640
640 to 1279.999998	320 to 639.999999	2	640 to 900 900 to 1280
*1280 to 2559.999996	320 to 639.999999	4	1280 to 1800 1800 to 2560
*8663A only.			

HP 8663A. Each character consists of 1 byte, 8 bits per byte. This string contains 2 "fast learn" characters to instruct the instrument to interpret the subsequent data as fast learn information, 5 characters that contain the fundamental band frequency data, 1 character that contains the range data, and the final characters contain modulation information. The string configuration is shown in Figure 12.2, Fast Learn Character String.

The data strings can be set up by either of two methods, reading or "learning" the string from the synthesizer and storing it to be output later, or by programming the controller to assemble the string. When the string is read from the synthesizer in the fast learn mode, the

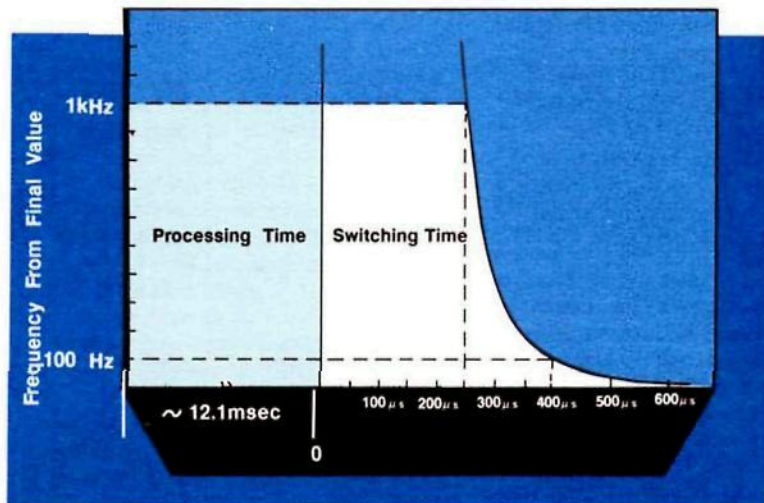

Figure 12.1. Typical frequency switching times.

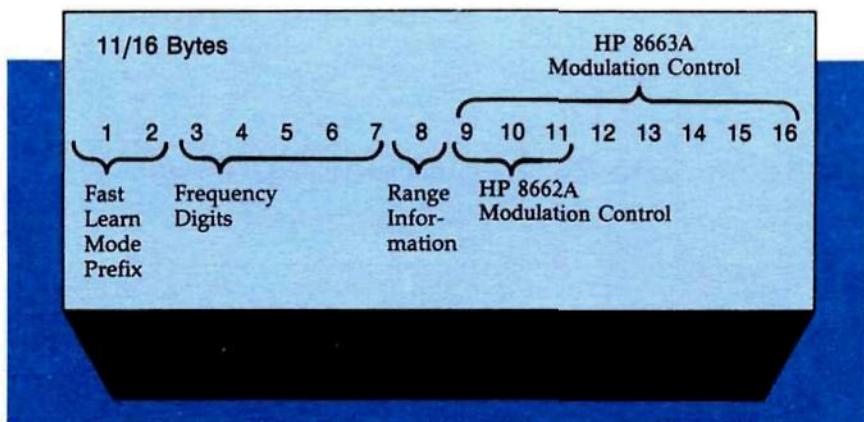

Figure 12.2 Fast Learn Character String

front panel of the instrument is set to the desired frequency and modulation (all functions except phase modulation and amplitude can be programmed in the fast learn mode). The controller reads the ranged and scaled binary data from the HP 8662A/8663A and stores it in an array. The data in the array is then output to the HP 8662A/8663A for fast switching. This alleviates the need for the operator to know how to format the fast learn string.

If many frequencies are to be output to the HP 8662A/ 8663A, in a random or real time fashion, it may be more practical for the external controller to format the fast learn strings. Figure 12.2 and Table 12.2 show the structure of the binary coded data and give an example to realize 812.62345 MHz. The first two bytes of the string are the fast learn mode prefix, these are always the same in the fast learn mode, whether the

instrument configures the data string or the controller. Bytes 3 through 7 represent the frequency digits, byte 3 being the least significant digit. Two decimal characters are contained in each byte in BCD format. Byte 8 contains the range information, the range information is not coded in any particular manner and is listed in Table 12.3, Fast Learn Characters. Bytes 9 through 11/16 contain the modulation control data.

From Table 12.1, to scale the example frequency of 812.62345 MHz to the fundamental band, the frequency is divided by 2. Each digit in the resulting fundamental frequency is converted to a

Byte	Bits	Information
1	0100 0000	Fast Learn mode prefix
2	0011 1001	Fast Learn mode prefix
		Least significant digits:
3	0101 0000	40631172 5.0 Hz
4	0111 0010	406311 72 5.0 Hz
5	0001 0001	4063 11 725.0 Hz
6	0110 0011	40 63 11725.0 Hz
7	0100 0000	40 6311725.0 Hz
8	0001 0101	Range 640 to 899.999998 MHz
9-11/16		Modulation control bytes.
Example:		Frequency = 812.62345 MHz
Scale to fundamental:		812.62345/2 = 406311725.0 Hz

Table 12.2 Fast Learn Character String Example

4-bit binary equivalent, bytes 3 through 7 in Table 12.2. The range data is found in Table 12.3. The complete string of 11/16 bytes is stored by the controller and output over the HP-IB in 8-bit bytes. On receipt of the 11/16th byte, the HP 8662A/8663A clocks the binary data from the frequency control board out to the rest of the instrument.

Figure 12.3 presents typical fast learn software using an HP 9836 series 200 controller. The program first reads the front panel setting of the HP 8662A/8663A and stores this string in an array. This sets up a fast learn string that contains the fast learn mode characters, frequency and range data for 100 MHz, and preset modulation conditions. The program then manipulates bytes 3 through 8, the frequency and range bytes. As each frequency is input it is scaled to the fundamental band, the digits are converted to binary by translating them two at a time to their ASCII equivalent (starting with the most significant digits). The appropriate range information is selected, and the resulting characters replace bytes 3 through 8 in the original fast learn string. After the last frequency is input, the program concatenates the 11/16 byte words and outputs them to the HP 8662A/8663A. In the fast learn mode this frequency data bypasses the microprocessor, is fed directly to the frequency latch board and instrument switching time is reduced from 12.5 msec to 420/510 μ sec.

Byte	Bits/Byte	Comments
1	0100 0000	"Fast" learn mode prefix
2	0011 1001	"Fast" learn mode prefix
3	xxxx xxxx	Bytes 3-7 contain the frequency digits scaled to the fundamental band of the HP 8662A/8663A (320 to 639.9999999 MHz). The first four bits of byte 7 contain the most significant digit, all digits are in BCD.
4	xxxx xxxx	
5	xxxx xxxx	
6	xxxx xxxx	
7	xxxx xxxx	
8	xxxx xxxx	Range control data, the following binary codes represent valid range data: 0000 0100 320-449.9999999 MHz 0000 0000 450-639.9999999 MHz 0110 1001 .1-.1499999 MHz 0100 1001 .15-.9999999 MHz 0100 1001 .15-.9999999 MHz 0010 1001 1-10 MHz 0000 1001 10-119.9999999 MHz 0000 0011 120-159.9999999 MHz 0000 0110 160-219.9999999 MHz 0000 0001 220-319.9999999 MHz 0001 0101 640-899.999998 MHz 0001 0001 900-1279.9999998 MHz 0001 1101 1280-1799.9999996 MHz HP 8663A only. 0001 1001 1800-2559.9999996 MHz
9-11/16		Modulation I/O control, preset condition.

Note: X's represent data inputs that will change according to the frequency to be programmed.

Table 12.3
"Fast" Learn Characters

```

10          ! FAST LEARN PROGRAMMING !
20  COM /Freq_data/ Freq_num$(25),Fast_switch$(1002)[16],
   Fast_out$(16002),Fast_learn$(16)
30  COM /Freq_data/ Freq_enter$(1001)[16],Freq_input
   $(1001)[16],Number,Cycle
41  ALPHA OFF
42  CALL Clearscreen
50  PRINT "The address of the 8662A/8663A is assumed to
   be 719."
60  ! INITIALIZE THE 8662A/8663A IN THE FAST LEARN MODE
70  REMOTE 7
80  OUTPUT 719;"SP00" ! SETS 8662A/8663A TO 100MHz, -30 dBm
90  OUTPUT 719;"L2" ! CONFIGURES 8662A/8663A IN FAST LEARN MODE
100 INPUT "Will you be addressing an 8662A (2) or 8663A (3)?",A
104 ALPHA ON
110 IF A=2 THEN
120 ENTER 719 USING "#,11A";Fast_learn$ ! READ PRESET
   CONDITIONS FROM 8662A
130 GOTO Main
140 END IF
150 ENTER 719 USING "#,16A";Fast_learn$ ! READ PRESET
   CONDITIONS FROM 8663A
160 Main:CALL Clearscreen
170 !
180 !
190 CALL Input
200 CALL Fast_out
210 CALL Cycle
220 CALL Start
230 CALL Stop
240 CALL Erase
250 END
260 !
270 !
280 Input:SUB Input
290  COM /Freq_data/ Freq_num$(25),Fast_switch$(1001)[16],
   Fast_out$(16001),Fast_learn$(16)
300  COM /Freq_data/ Freq_enter$(1001)[16],Freq_input
   $(1001)[16],Number,Cycle
305 Input2: ! ENTER FAST LEARN FREQUENCIES
306  CALL Clearscreen
310 PRINT "When all desired frequencies have been entered,
   input 0."

```

Figure 12.3.
Fast learn programming

```

330     Number=Number+1
340     INPUT "Enter frequency in MHz.",Freq_input$(Number)
350     IF Freq_input$(Number)="0" THEN
360         Number=Number-1
370         SUBEXIT
380     END IF
390     CALL Create_bytes
400     GOTO Input2
410     SUBEND
420     |
430     |
440 Create_bytes:SUB Create_bytes
450     COM /Freq_data/ Freq_num$(25),Fast_switch$(1001)[16],
Fast_out$(16001),Fast_learn$(16)
460     COM /Freq_data/ Freq_enter$(1001)[16],Freq_input$(
(1001)[16],Number,Cycle
470     |
480     | SCALE ENTERED FREQUENCIES TO FUNDAMENTAL BAND OF
8662A/8663A
490     |
500     Freqval=VAL(Freq_input$(Number))
510     SELECT Freqval
520     CASE <120
530     Freq_enter$(Number)=VAL$(520+Freqval)
540     CASE <160
550     Freq_enter$(Number)=VAL$(Freqval+4)
560     CASE <320
570     Freq_enter$(Number)=VAL$(Freqval+2)
580     CASE <640
590     Freq_enter$(Number)=Freq_input$(Number)
600     CASE <1280
610     Freq_enter$(Number)=VAL$(Freqval/2)
620     CASE <2560
630     Freq_enter$(Number)=VAL$(Freqval/4)
640     END SELECT
650     |
660     | FIND DECIMAL POSITION OF THE ENTERED FREQUENCY.
670     |
680     Freq_num$="000"&Freq_enter$(Number)&"0000000"
690     Fast_switch$(Number)=Fast_learn$
700     Dec_pos=POS(Freq_num$,".")
710     |
720     | IF NO DECIMAL ENTERED - ADD A DECIMAL POINT.
730     |
740     IF Dec_pos=0 THEN GOTO 800
750     Freq_num$="000"&Freq_enter$(Number)&".0000000"
760     Dec_pos=POS(Freq_num$,".")
770     |
780     | CHANGE BYTES 7,6,5,4,3, OF FAST LEARN STRING TO
ACCOMADATE NEW FREQ.
790     |
800     | FORM BYTE 7 OF FAST SWITCH STRING
810     Fast_switch$(Number)[7;1]=CHR$(16+VAL(Freq_num$(Dec
_pos-3;1))+VAL(Freq_num$(Dec_pos-2;1)))
820     |
830     | FORM BYTE 6
840     Fast_switch$(Number)[6;1]=CHR$(16+VAL(Freq_num$(Dec
_pos-1;1))+VAL(Freq_num$(Dec_pos+1;1)))
850     |
860     | FORM BYTE 5
870     Fast_switch$(Number)[5;1]=CHR$(16+VAL(Freq_num$(Dec
_pos+2;1))+VAL(Freq_num$(Dec_pos+3;1)))
880     |
890     | FORM BYTE 4
900     Fast_switch$(Number)[4;1]=CHR$(16+VAL(Freq_num$(Dec
_pos+4;1))+VAL(Freq_num$(Dec_pos+5;1)))
910     |
920     | FORM BYTE 3
930     Fast_switch$(Number)[3;1]=CHR$(16+VAL(Freq_num$(Dec
_pos+6;1))+VAL(Freq_num$(Dec_pos+7;1)))
940     |
950     | FORM BYTE 8
960     | BYTE 8 OF FAST LEARN STRING CONTAINS RANGE DATA.
970     | CONTROLS FREQUENCY CONVERSION, ALC BANDWIDTH, LPF
SELECTION.
980     Range=VAL(Freq_input$(Number))
990     SELECT Range
1000    CASE <.15
1010    Fast_switch$(Number)[8;1]=CHR$(105)
1020    CASE <1
1030    Fast_switch$(Number)[8;1]=CHR$(73)
1040    CASE <10
1050    Fast_switch$(Number)[8;1]=CHR$(41)
1060    CASE <120
1070    Fast_switch$(Number)[8;1]=CHR$(9)
1080    CASE <160
1090    Fast_switch$(Number)[8;1]=CHR$(3)
1100    CASE <220
1110    Fast_switch$(Number)[8;1]=CHR$(6)
1120    CASE <320
1130    Fast_switch$(Number)[8;1]=CHR$(1)
1140    CASE <450
1150    Fast_switch$(Number)[8;1]=CHR$(4)
1160    CASE <640
1170    Fast_switch$(Number)[8;1]=CHR$(0)
1180    CASE <900
1190    Fast_switch$(Number)[8;1]=CHR$(21)
1200    CASE <1280
1210    Fast_switch$(Number)[8;1]=CHR$(17)
1220    CASE <1800
1230    Fast_switch$(Number)[8;1]=CHR$(29)
1240    CASE <=2560
1250    Fast_switch$(Number)[8;1]=CHR$(25)
1260    END SELECT
1270    |
1280    SUBEND
1290    |
1300    |
1310    SUB Fast_out
1320    COM /Freq_data/ Freq_num$(25),Fast_switch$(1001)[16],
Fast_out$(16001),Fast_learn$(16)
1330    COM /Freq_data/ Freq_enter$(1001)[16],Freq_input
$(1001)[16],Number,Cycle
1331    | CREATES STRING OF FAST LEARN BYTES
1340    Fast_out$=""
1350    FOR I=1 TO Number
1360    Fast_out$=Fast_out$&Fast_switch$(I)
1370    NEXT I
1380    SUBEND
1390    |
1400    |
1410 Start:SUB Start
1420    COM /Freq_data/ Freq_num$(25),Fast_switch$(1001)[16],
Fast_out$(16001),Fast_learn$(16)
1430    COM /Freq_data/ Freq_enter$(1001)[16],Freq_input
$(1001)[16],Number,Cycle
1431    | OUTPUT FAST LEARN STRING TO 8662A/8663A
1432    CALL Clearscreen
1440    PRINT "Press CONTINUE when ready to begin Fast
Switching."
1450    PAUSE
1460    IF Cycle<1 THEN Cycle=1
1470    FOR I=1 TO Cycle
1480    OUTPUT 719 USING "#,K";Fast_out$
1490    NEXT I
1500    SUBEND
1510    |
1520    |
1530 Cycle:SUB Cycle
1540    COM /Freq_data/ Freq_num$(25),Fast_switch$(1001)[16],
Fast_out$(16001),Fast_learn$(16)
1550    COM /Freq_data/ Freq_enter$(1001)[16],Freq_input
$(1001)[16],Number,Cycle
1553    CALL Clearscreen
1560    INPUT "Cycle frequency group ? times.",Cycle
1570    SUBEND
1580    |
1590    |
1600 Erase:SUB Erase
1610    COM /Freq_data/ Freq_num$(25),Fast_switch$(1001)[16],
Fast_out$(16001),Fast_learn$(16)
1620    COM /Freq_data/ Freq_enter$(1001)[16],Freq_input
$(1001)[16],Number,Cycle
1630    INPUT "Erase entered frequencies? (Y,N),Y$
1640    IF Y$="Y" THEN
1641    Fast_out$=""
1642    FOR I=1 TO Number
1643    Fast_switch$(I)=CHR$(0)
1644    NEXT I
1645    Number=0
1646    Cycle=0
1647    CALL Clearscreen
1649    PRINT "Frequencies and number of cycles have
been erased."
1680    END IF
1690 DISP "Program ended. Press RUN if you wish to continue."
1810 SUBEND
1820 |
1830 |
1840 Stop: SUB Stop
1841 CALL Clearscreen
1850 Stop$="!" | OUTPUT A DUMMY BYTE
1860 OUTPUT 719 USING "#,1A";Stop$
1870 PRINT "Fast Switching complete."
1880 SUBEND
1890 Clearscreen:SUB Clearscreen
1891 ALPHA OFF
1900 OUTPUT 1 USING "#,@"
1910 ALPHA ON
1920 SUBEND

```

Figure 12.3.
Fast learn programming

Fast Frequency Switching Option H-50

The H-50 Option is similar to the fast learn mode in that it circumvents the HP 8662A/8663A microprocessor, sending data directly to frequency and range data latches. The basic difference between fast learn and option H-50 is that the data to the frequency and range latches is input from an external 50-pin parallel interface on the back panel of the instrument. This provides direct binary frequency input to the HP 8662A/8663A so that it can be interfaced with a device under test or other equipment in a test system. Frequency can be controlled through HP-IB with an appropriate interface board to provide the parallel inputs to the H-50 connector. Option H-50 will control only frequency, other functions must be set either from the front panel or via the normal HP-IB port.

Table 12.4 defines option H-50 connector pins and corresponding frequency and range control inputs. The frequency and range data inputs respond to TTL positive-true logic levels, the DFI (Direct Frequency Interface) line requires a TTL low level to enable the H-50 option. The Data Valid line clocks the frequency and range data into the DFI latches on a TTL positive transition. For example, to switch the HP 8662A/8663A to 812.62345 MHz, the frequency is first scaled to the fundamental band, to 406.311725 MHz, and each digit translated to a 4 bit binary equivalent as shown in the example column of Table 12.4. The appropriate coded range data, 640 to 900 MHz, is selected from Table 12.5. TTL levels corresponding to a "1" or "0" applied to the appropriate connector pins cause the HP 8662A/8663A to switch in 400 μ sec to within 100 Hz accuracy upon receipt of a Data

Valid line TTL positive transition.

Summary

The Fast Learn mode and Option H-50 provide extremely fast switching of the HP 8662A/8663A while maintaining the spectral purity of the synthesizer. The fast learn mode is advantageous where programming flexibility is required, as in ATE systems. In this mode simple HP-IB control of the HP 8662A/8663A provides fast frequency switching with modulation control, and remote programming of other normal instrument functions. The H-50 option is well suited to dedicated dynamic testing of secure communications receivers and frequency hopping systems, or other tests that require synchronous frequency switching.

Connector Pin	Bit Designation	Digit/Range	Example: 812.62345 MHz/2 = 4063117250 Hz Binary Decimal	Connector Pin	Bit Designation	Digit/Range	
1	DF9-1	100's MHz	0	27	DF2-1	10's Hz	0 2
2	DF9-2		0	28	DF2-2		1
3	DF8-1	10's MHz	0 0	29	DF2-4		0
4	DF8-2		0	30	DF2-8		0
5	DF8-4		0	31	DF1-1	1's Hz	1 5
6	DF8-8		0	32	DF1-2		0
7	DF7-1	1's MHz	0 6	33	DF1-4		1
8	DF7-2		1	34	DF1-8		0
9	DF7-4		1	35	DF0-1	.1's Hz	0 0
10	DF7-8		0	36	DF0-2		0
11	DF6-1	100's KHz	1 3	37	DF0-4		0
12	DF6-2		1	38	DF0-8		0
13	DF6-4		0	39	R0	Range Select	1
14	DF6-8		0	40	R1	Range Select	0
15	DF5-1	10's KHz	1 1	41	R2	Range Select	1
16	DF5-2		0	42	R3	Range Select	0
17	DF5-4		0	43	R4	Range Select	1
18	DF5-8		0	44	R5	Range Select	0
19	DF4-1	1's KHz	1 1	45	R6	Range Select	0
20	DF4-2		0	46	N/C		X
21	DF4-4		0	47	N/C		X
22	DF4-8		0	48	DFI Enable		0
23	DF3-1	100's Hz	1 7	49	Data Valid		1
24	DF3-2		1	50	Ground		X
25	DF3-4		1				
26	DF3-8		0				

Table 12.4
H-50 connector pin outs.

NOTE:

The lower 9 digits of the frequency data, 10's MHz through .1's Hz (DF8-DF0), are represented by a 4-bit BCD code. The weighting of each of the bits is indicated by the "-1" through "-8" suffix to the bit designation (e.g., DF8-1 is the LSB for

digit 8 and DF8-8 is the MSB for digit 8). The 100's MHz digit is represented by the lower two bits of a 4-bit BCD code for decimal values between 3 and 6 inclusive. Since these are the only values that this digit can validly assume, there is no need for a full 4-bit BCD representation.

100's MHz Decimal Value	DF9-1	DF9-2
3	1	1
4	0	0
5	1	0
6	0	1

The range data is not coded in any particular manner. The values that the individual bits must assume for a given frequency range are indicated in Table 12.5.

Frequency Range (MHz)	Range Data						
	R0	R1	R2	R3	R4	R5	R6
$f_0 < .15$	1	0	0	1	0	1	1
$.15 < f_0 < 1$	1	0	0	1	0	0	1
$1 < f_0 < 10$	1	0	0	1	0	1	0
$10 < f_0 < 120$	1	0	0	1	0	0	0
$120 < f_0 < 160$	1	1	0	0	0	0	0
$160 < f_0 < 220$	0	1	1	0	0	0	0
$220 < f_0 < 320$	1	0	0	0	0	0	0
$320 < f_0 < 450$	0	0	1	0	0	0	0
$450 < f_0 < 640$	0	0	0	0	0	0	0
$640 < f_0 < 900$	1	0	1	0	1	0	0
$900 < f_0 < 1280$	1	0	0	0	1	0	0
*1280 < f_0 < 1800	1	0	1	1	1	0	0
*1800 < f_0 < 2560	1	0	0	1	1	0	0

f_0 = Output frequency of the instrument
*8663A only.

Table 12.5
H-50 range data coding.

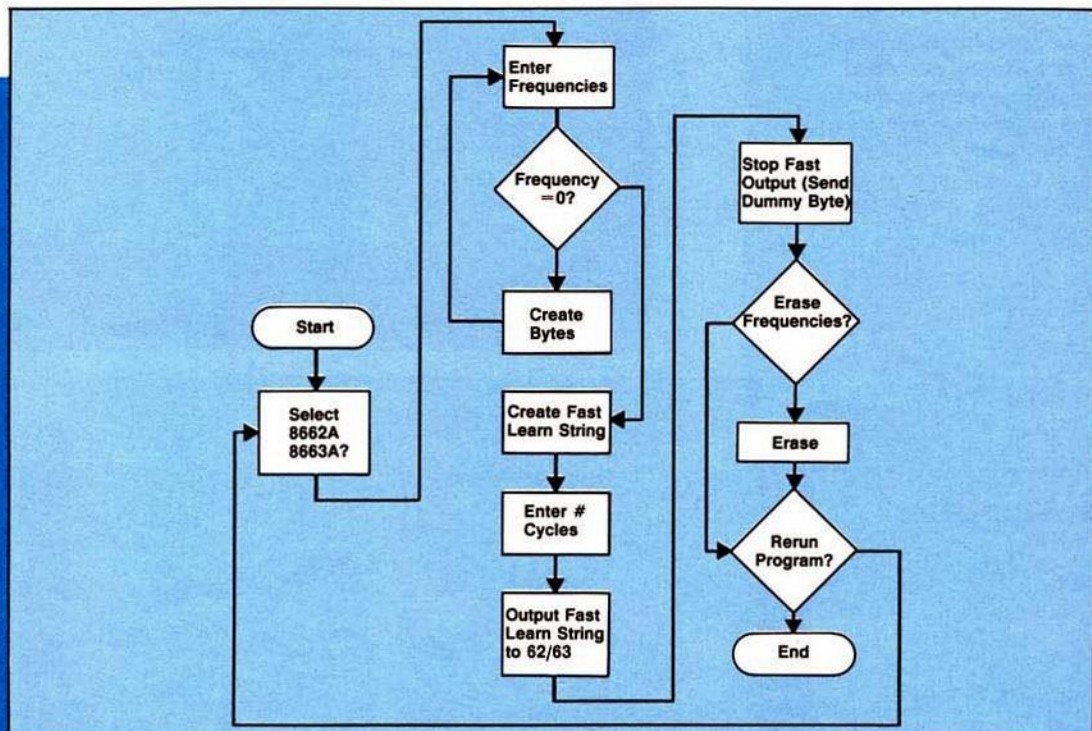

Figure 12.4.
Flow chart for Fast Learn Program

A

Calculation of Phase Noise of Three Unknown Sources

Given three unknown sources: 1, 2, and 3. Using the two source technique, measure each source against each other source in three measurements, yielding

$$P_{12} = \mathcal{L} \text{ measured of sources 1 and 2 in dBc,}$$

$$P_{23} = \mathcal{L} \text{ measured of sources 2 and 3 in dBc,}$$

$$P_{13} = \mathcal{L} \text{ measured of sources 1 and 3 in dBc.}$$

The phase noise performance of each source may be calculated from the following formulas:

$$\mathcal{L}_1 \text{ in dBc} = 10 \log \left[\frac{10^{\frac{P_{12}}{10}} + 10^{\frac{P_{13}}{10}} - 10^{\frac{P_{23}}{10}}}{2} \right]$$

$$\mathcal{L}_2 \text{ in dBc} = 10 \log \left[\frac{10^{\frac{P_{12}}{10}} + 10^{\frac{P_{23}}{10}} - 10^{\frac{P_{13}}{10}}}{2} \right]$$

$$\mathcal{L}_3 \text{ in dBc} = 10 \log \left[\frac{10^{\frac{P_{13}}{10}} + 10^{\frac{P_{23}}{10}} - 10^{\frac{P_{12}}{10}}}{2} \right]$$

B

10 MHz Low Noise Bandpass Amplifier

Hewlett-Packard assumes no responsibility for the use of any circuits described herein and makes no representations or warranties, express or implied, that such circuits are free from patent infringement.

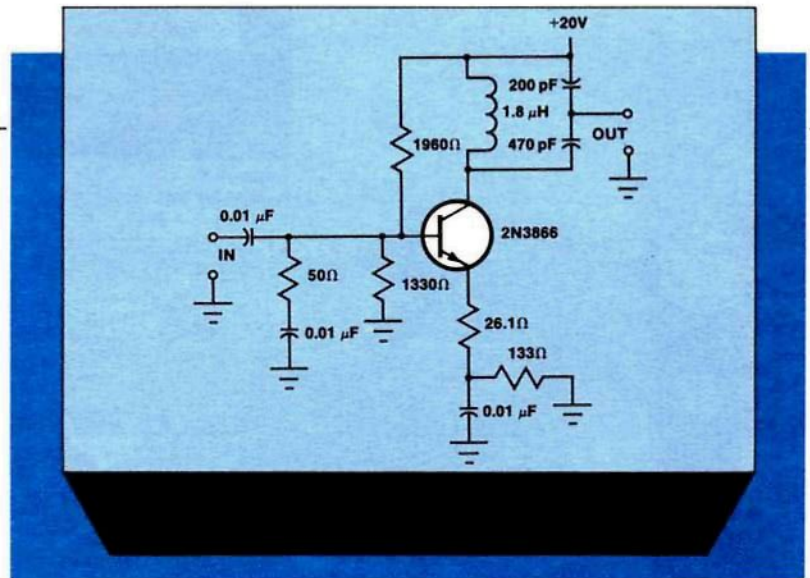

C

Low Noise Amplifier

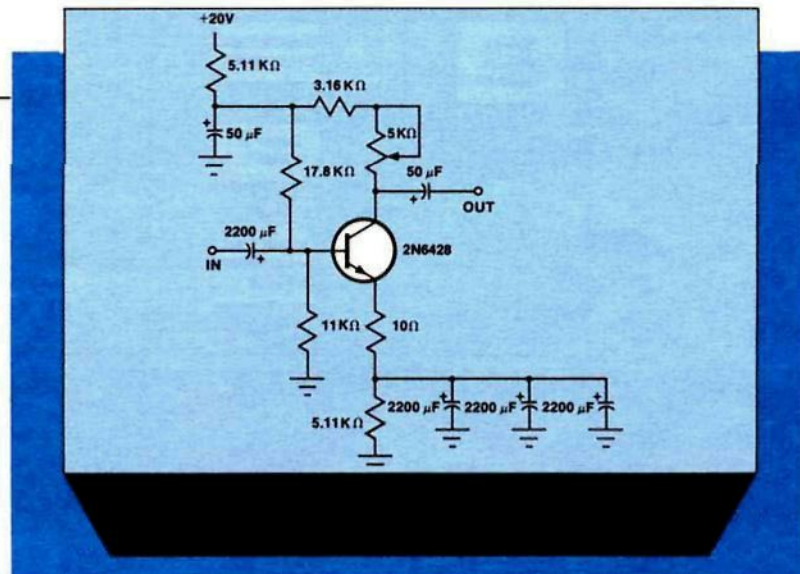

D

References

Hewlett-Packard Application Notes

- AN 207 Understanding and Measuring Phase Noise in the Frequency Domain
- AN 150-4 Spectrum Analysis . . . Noise Measurements
- AN 270-2 Automated Noise Sideband Measurements Using the HP 8568A Spectrum Analyzer
- AN 225 Measuring Phase Spectral Density of Synthesized Signal Sources Exhibiting f and f Noise Characteristics with the 5390A Frequency Stability Analyzer
- AN 286-1 Applications and Operation of the 8901A Modulation Analyzer
- AN 218-1 Applications and Performance of the 8671A and 8672A Microwave Synthesizers
- AN 246-2 Measuring Phase Noise with the HP 3585A Spectrum Analyzer
- AN 983 Comb Generator Simplifies Multiplier Design
- PN 11729B-1 Phase Noise Characterization of Microwave Oscillators Phase Detector Method
- PN 11729C-2 Phase Noise Characterization of Microwave Oscillators Frequency Discriminator Method

Other References

1. D. Scherer (H-P), "Design Principles and Test Methods of Low Phase Noise RF and Microwave Sources", Hewlett-Packard RF and Microwave Symposium, October 1987. (Also edited version in *Microwaves*, "Today's Lesson—Learn about Low-Noise" Part 1, pp. 116-122, April 1979, Part pp. 72-77, May 1979.)
2. Hewlett-Packard Journal, February 1981, Volume 32, No. 2.
3. Fischer, M. (H-P), "Frequency Stability Measurement Procedures", presented at the 8th Annual Precision Time and Time Interval Meeting, December 1976.
4. A.L. Lance, W.D. Seal, F.G. Mendoza, and N.W. Hudson (TRW), "Automated Phase Noise Measurements", *Microwave Journal*, June 1977.
5. "Frequency Domain Stability Measurements: A Tutorial Introduction", David A. Howe, N.B.S. Technical Note 679, National Bureau of Standards, Boulder Colorado, 80302, 1976.
6. McNamee, M.(H-P), "Automate for Improved Phase Noise Measurement", *Microwaves*, May 1979.
7. Giacoletto, L., "Electronics Designer's Handbook", Second Edition, McGraw-Hill, 1977, pp. 26-32.
8. D. Scherer (H-P), "Generation of Low Phase Noise Microwave Signals", HP RF and Microwave Measurement Symposium, May 1981.
9. R. Temple (H-P), "Choosing a Phase Noise Measurement Technique", HP RF and Microwave Measurement Symposium, Jan 1983.
10. D. Scherer (H-P), "Art of Phase Noise Measurements", HP RF and Microwave Measurement Symposium, May 1983.
11. R. Burns (H-P), "8901B Adjacent Channel Power", HP RF and Microwave Measurement Symposium, May 1983.

For more information,
call your local HP sales office listed
in the telephone directory white pages.
Or write to Hewlett-Packard:

United States:

Hewlett-Packard
P.O. Box 10301
Palo Alto, CA 94303-0890

Europe:

Hewlett-Packard S.A.
P.O. Box 529
1180 AM Amstelveen, the Netherlands

Canada:

Hewlett-Packard Ltd.
6877 Goreway Drive
Mississauga, Ontario L4V 1M8

Japan:

Yokogawa-Hewlett-Packard Ltd.
29-21, Takido-Higashi, 3-Chome
Suginami-ku, Tokyo 168

Elsewhere in the world:

Hewlett-Packard Intercontinental
3495 Deer Creek Road
Palo Alto, CA 94304



Data Subject to Change
December 1986

Printed in U.S.A.
5953-8435